

Calcolo perdite di carico nei canali aria

Lunghezza 50 m
 Portata 4000 m3/h
 1,11 m3/s
 Diametro 0,5 m
 Area 0,19625 m2
 Viscosità 1,50E-05 m2/s aria a 20°C

Velocità 5,66 m/s
 rugosità 0,000060 m lamiera Al liscie
 rug. Rel 0,000120

Re 188724
 f attrito 0,0167

$$f = \frac{1,325}{\left[\ln\left(\frac{s}{3,7} + 5,74 Re^{-0,9} \right) \right]^2}$$

Perdite di carico distribuite

Yd 2,79 m
 Δp d 32,83 Pa

Perdite di carico localizzate

ΣK 12,2
 Yloc 19,74 m
 Δp l 232,39 Pa

In totale abbiamo quindi

Y tot 22,53 m
 Δp 265,22 Pa

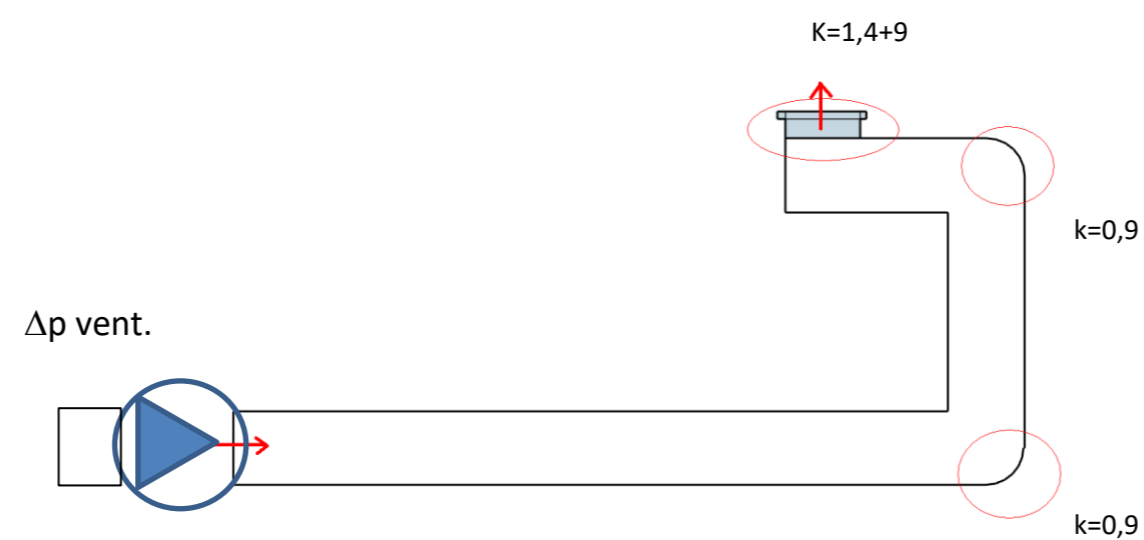
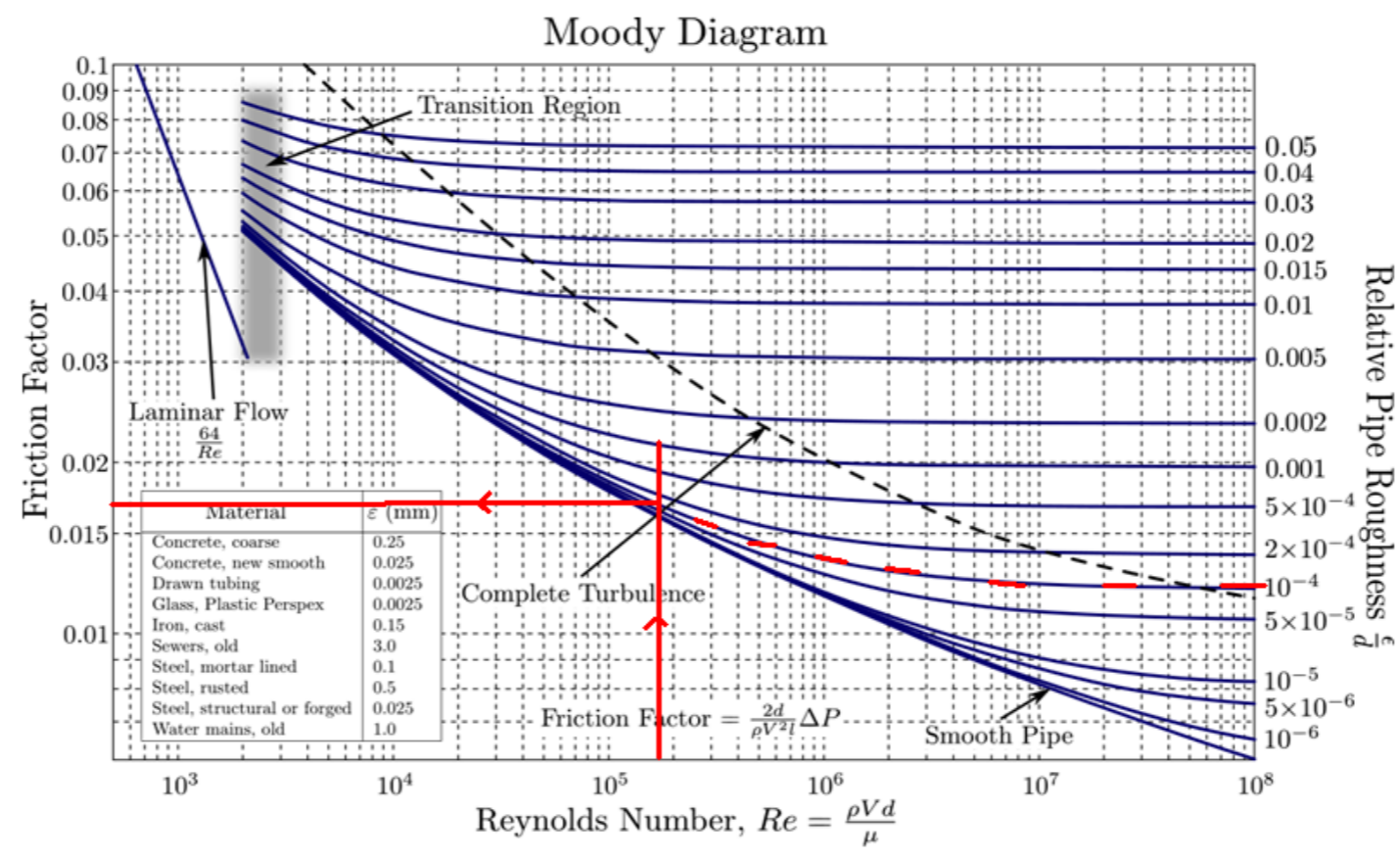

- Perdite di carico localizzate K**
- curva stretta 0,9
 - una derivazione 1,3
 - restringimento dolce 0,2
 - curva a spigolo vivo 1,4
 - una bocchetta 9

NB: il ventilatore deve avere una pressione utile superiore 265,22 PA

Calcolo perdite di carico nei canali aria

TRATTO AB

Lunghezza	50 m
Portata	4000 m ³ /h 1,11 m ³ /s
Diametro	0,5 m
Area	0,19625 m ²
Viscosità	1,50E-05 m ² /s aria a 20°C
Velocità	5,66 m/s
rugosità	0,000060 m lamiera Al liscie
rug. Rel	0,000120
Re	188724
f attrito	0,0167

Perdite di carico distribuite

Y _d	2,79 m
Δp _d	32,83 Pa

Perdite di carico localizzate ΣK

ΣK	0
----	---

Y _{loc}	0,00 m
Δp _l	0,00 Pa

In totale lungo AB abbiamo quindi

Y _{tot}	2,79 m
Δp _{AB}	32,83 Pa

TRATTO BD

Lunghezza	30 m
Portata	2500 m ³ /h 0,69 m ³ /s
Diametro	0,4 m
Area	0,1256 m ²
Viscosità	1,50E-05 m ² /s aria a 20°C
Velocità	5,53 m/s

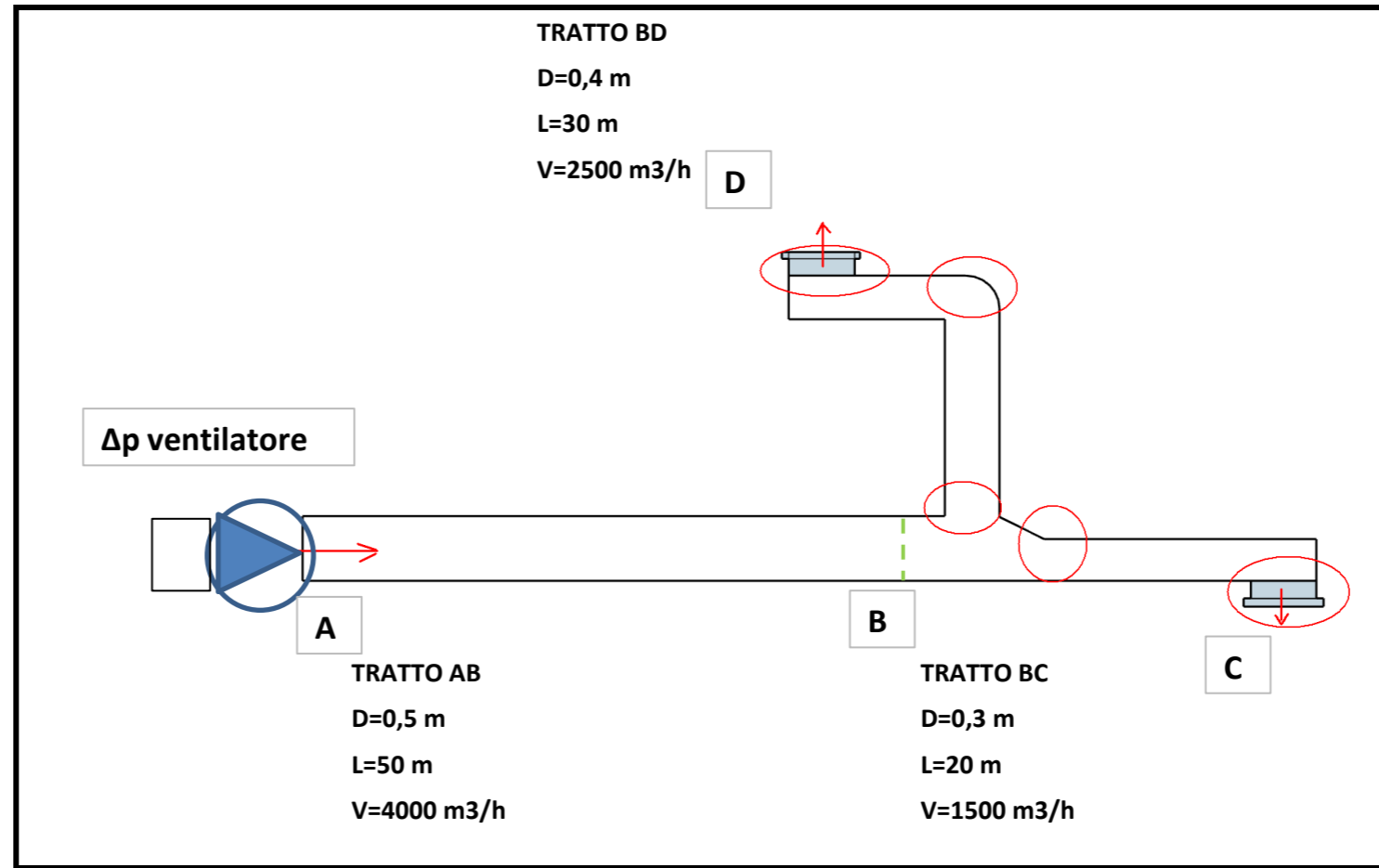

TRATTO	Perdita	Bocche	Perdita
AB	32,83 Pa	C	278,23 Pa
BC	245,40 Pa	D	286,42 Pa --> +sfavorita
BD	253,59 Pa		

NB: il ventilatore deve avere una pressione utile superiore a 286,42 Pa

Perdite di carico localizzate ΣK

curva stretta	0,9
una derivazione	1,3
restringimento	0,2
curva a spigolo	1,4
una bocchetta	9

rugosità 0,000060 m lamiera Al liscie
rug. Rel 0,000150

Re 147440
f attrito 0,0176

Perdite di carico distribuite

Yd 2,10 m
 $\Delta p d$ 24,70 Pa aria a 20°C con densità 1,2

Perdite di carico localizzate ΣK

ΣK 12,6 =1,3+0,9+1,4+9

Yloc 19,44 m
 $\Delta p l$ 228,89 Pa

In totale lungo AB abbiamo quindi

Y tot 21,54 m
 $\Delta p BD$ 253,59 Pa

TRATTO BC

Lunghezza 20 m
Portata 1500 m³/h
0,42 m³/s
Diametro 0,3 m
Area 0,07065 m²
Viscosità 1,50E-05 m²/s aria a 20°C

Velocità 5,90 m/s
rugosità 0,000060 m lamiera Al liscie
rug. Rel 0,000200

Re 117952
f attrito 0,0185

Perdite di carico distribuite

Yd 2,23 m
 $\Delta p d$ 26,31 Pa aria a 20°C con densità 1,2

Perdite di carico localizzate ΣK

ΣK $10,6 = 0,2+1,4+9$

Y_{loc} $18,61$ m

$\Delta p I$ $219,09$ Pa

In totale lungo AB abbiamo quindi

Y_{tot} $20,85$ m

$\Delta p BC$ $245,40$ Pa

Perdite di carico aria MANDATA nel LABORATORIO AUTOMAZIONE

Portata singolo LAB. 604,8 m3/h
 Portata TOT. 1814,4 m3/h
 (NB: doppia in OFF.) 0,504 m3/s
 Diametro VMC 0,45 m
 Area 0,159 m2
 Velocità 3,17 m/s
 Viscosità 1,50E-05 m2/s aria a 20°C
 rugosità 9,0E-05 m lamiera liscie
 rug. Rel 2,0E-04

Coefficienti perdite carico localizzate

Diramazione T 1,2
 Derivazione ^ 90° 0,2 primario
 Derivazione > 90° 1,3 secondario
 Curva dolce 90° 0,5
 Curva spigolo 90° 1,4
 Restr. Dolce 0,2
 Bocchetta aperta 9

Per il calcolo delle perdite localizzate ci si muove dal monte verso valle e si considerano le perdite appena prima di arrivare alla lettera del tratto successivo

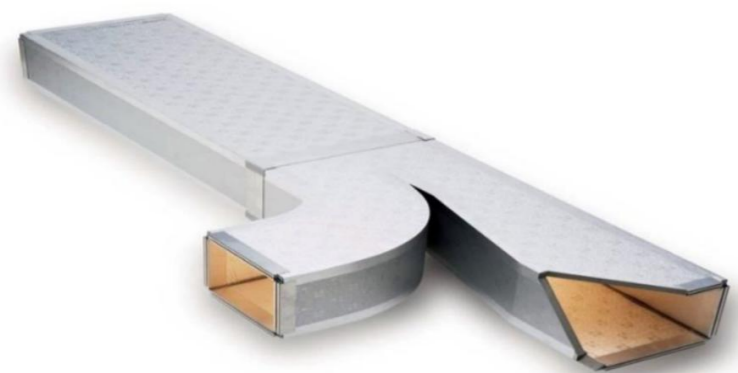
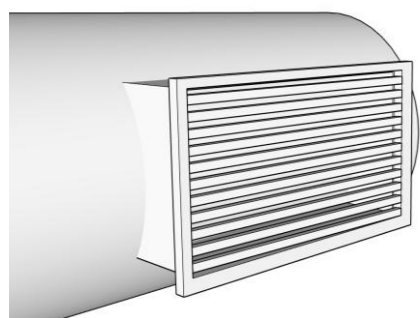

Bocchetta G	Lungh. [m]	Portata m3/h	D m	Velocità m/s	Re	f	Δp d [Pa]	Σk [Pa]	Δp l [Pa]	Δp tot [Pa]
OA	3,68	1814	0,35	5,24	122293	0,0184	3,19	1,4	23,1	26,3
AB	13,7	1210	0,35	3,49	81529	0,0197	5,64	0,2	1,5	7,1
BC	20,42	604,8	0,3	2,38	47558	0,0218	5,03	0,2	0,7	5,7
CD	3,9	604,8	0,3	2,38	47558	0,0218	0,96	0,7	2,4	3,3
DE	6,2	453,6	0,25	2,57	42803	0,0222	2,18	0,2	0,8	3,0
EF	6,2	302,4	0,2	2,68	35669	0,0231	3,07	0,2	0,9	3,9
FG	6,2	151,2	0,15	2,38	23779	0,0253	3,54	10,6	36,0	39,5
TOT										88,8 Pa

Bocchetta F	Lungh. [m]	Portata m3/h	D m	Velocità m/s	Re	f	Δp d [Pa]	Σk [Pa]	Δp l [Pa]	Δp tot [Pa]
OA	3,68	1814	0,35	5,24	122293	0,0184	3,19	1,4	23,1	26,3
AB	13,7	1210	0,35	3,49	81529	0,0197	5,64	0,2	1,5	7,1
BC	20,42	604,8	0,3	2,38	47558	0,0218	5,03	0,2	0,7	5,7
CD	3,9	604,8	0,3	2,38	47558	0,0218	0,96	0,7	2,4	3,3
DE	6,2	453,6	0,25	2,57	42803	0,0222	2,18	0,2	0,8	3,0
EF	6,2	302,4	0,2	2,68	35669	0,0231	3,07	10,5	45,1	48,2
TOT										93,5 Pa

Bocchetta E	Lungh. [m]	Portata m3/h	D m	Velocità m/s	Re	f	Δp d [Pa]	Σk [Pa]	Δp l [Pa]	Δp tot [Pa]
OA	3,68	1814	0,35	5,24	122293	0,0184	3,19	1,4	23,1	26,3
AB	13,7	1210	0,35	3,49	81529	0,0197	5,64	0,2	1,5	7,1
BC	20,42	604,8	0,3	2,38	47558	0,0218	5,03	0,2	0,7	5,7
CD	3,9	604,8	0,3	2,38	47558	0,0218	0,96	0,7	2,4	3,3
DE	6,2	453,6	0,25	2,57	42803	0,0222	2,18	10,5	41,6	43,7
TOT										86,1 Pa

Bocchetta D	Lungh. [m]	Portata m3/h	D m	Velocità m/s	Re	f	Δp d [Pa]	Σk [Pa]	Δp l [Pa]	Δp tot [Pa]
OA	3,68	1814	0,35	5,24	122293	0,0184	3,19	1,4	23,1	26,3
AB	13,7	1210	0,35	3,49	81529	0,0197	5,64	0,2	1,5	7,1
BC	20,42	604,8	0,3	2,38	47558	0,0218	5,03	0,2	0,7	5,7
CD	3,9	604,8	0,3	2,38	47558	0,0218	0,96	11	37,3	38,3
TOT										77,3 Pa

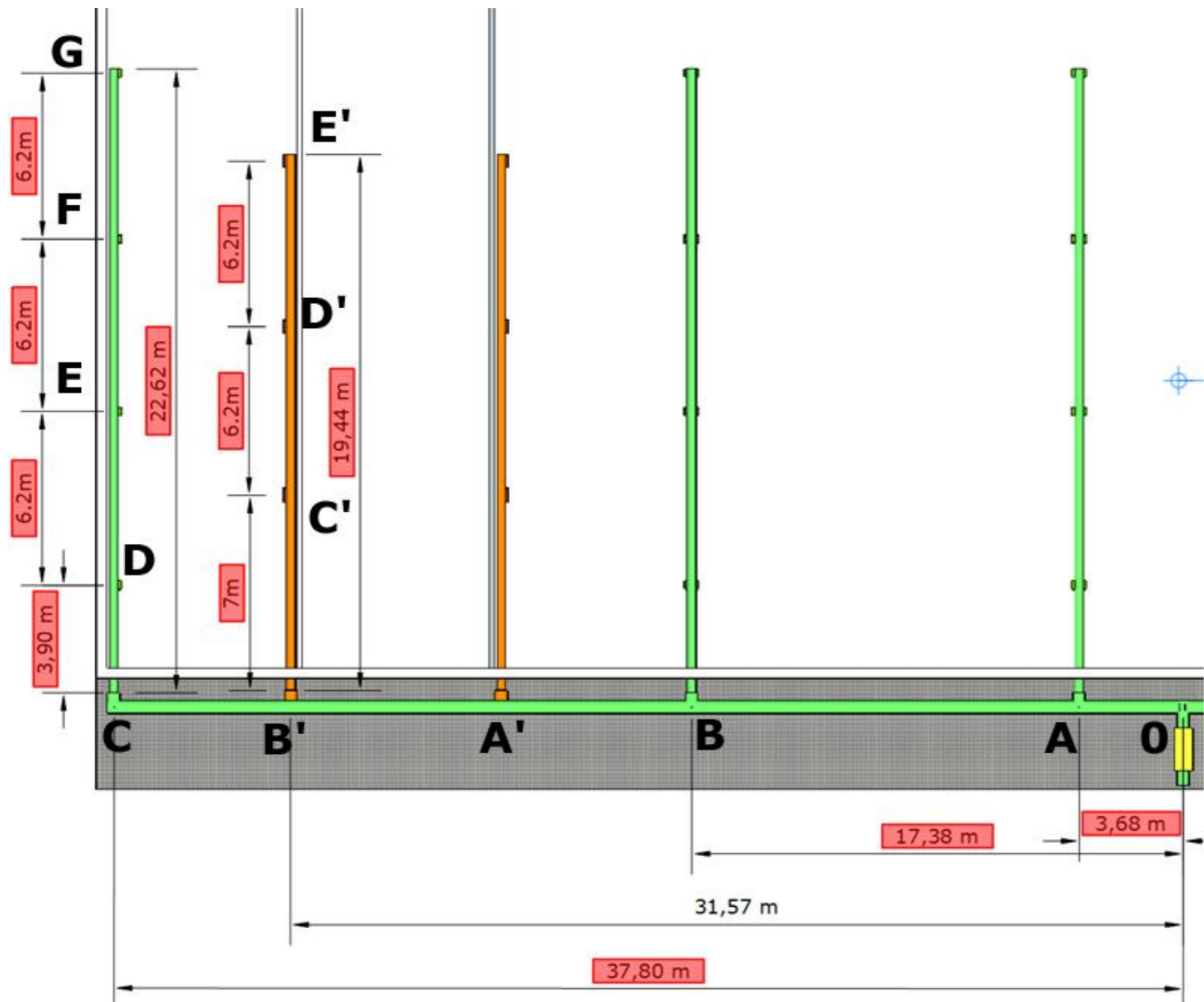

Perdite di carico aria RIPRESA nel LABORATORIO AUTOMAZIONE

Portata singolo LAB. 604,8 m³/h
 Portata TOT. 1814,4 m³/h
 (NB: doppia in OFF.) 0,504 m³/s
 Diametro VMC 0,45 m
 Area 0,159 m²
 Velocità 3,17 m/s
 Viscosità 1,50E-05 m²/s aria a 20°C
 rugosità 9,0E-05 m lamiera liscie
 rug. Rel 2,0E-04

Bocchetta E'	Lungh. [m]	Portata m ³ /h	D m	Velocità m/s	Re	f	Δp d [Pa]	Σk [Pa]	Δp l [Pa]	Δp tot [Pa]	
0A'	3,68	1814	0,35	5,24	122293	0,0184	3,19	1,4	23,1	26,3	
A'B'	13,7	1210	0,35	3,49	81529	0,0197	5,64	0,2	1,5	7,1	
B'C'	20,42	604,8	0,3	2,38	47558	0,0218	5,03	0,2	0,7	5,7	
C'D'	3,9	604,8	0,3	2,38	47558	0,0218	0,96	0,7	2,4	3,3	
D'E'	6,2	453,6	0,25	2,57	42803	0,0222	2,18	0,2	0,8	3,0	
									TOT	45,4	Pa

Coefficienti perdite carico localizzate

Diramazione T 1,2
 Derivazione ^ 90° 0,2 primario
 Derivazione > 90° 1,3 secondario
 Curva dolce 90° 0,5
 Curva spigolo 90° 1,4
 Restr. Dolce 0,2
 Bocchetta aperta 9

Per il calcolo delle perdite localizzate
 ci si muove dal monte verso valle e si
 considerano le perdite appena prima di
 arrivare alla lettera del tratto successivo

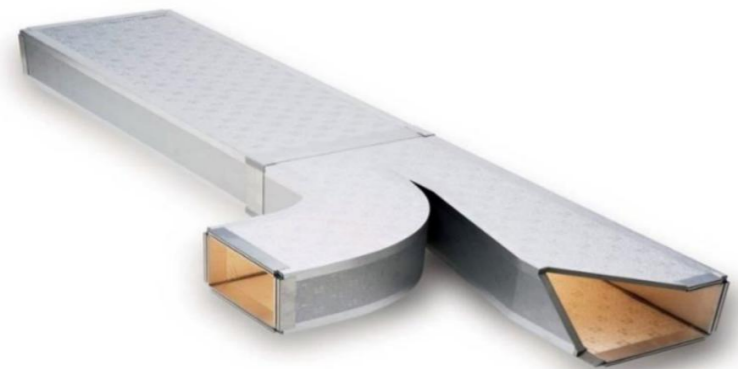
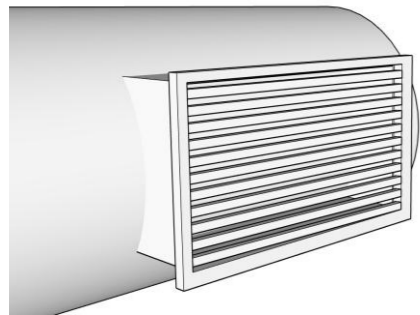

||

||

||

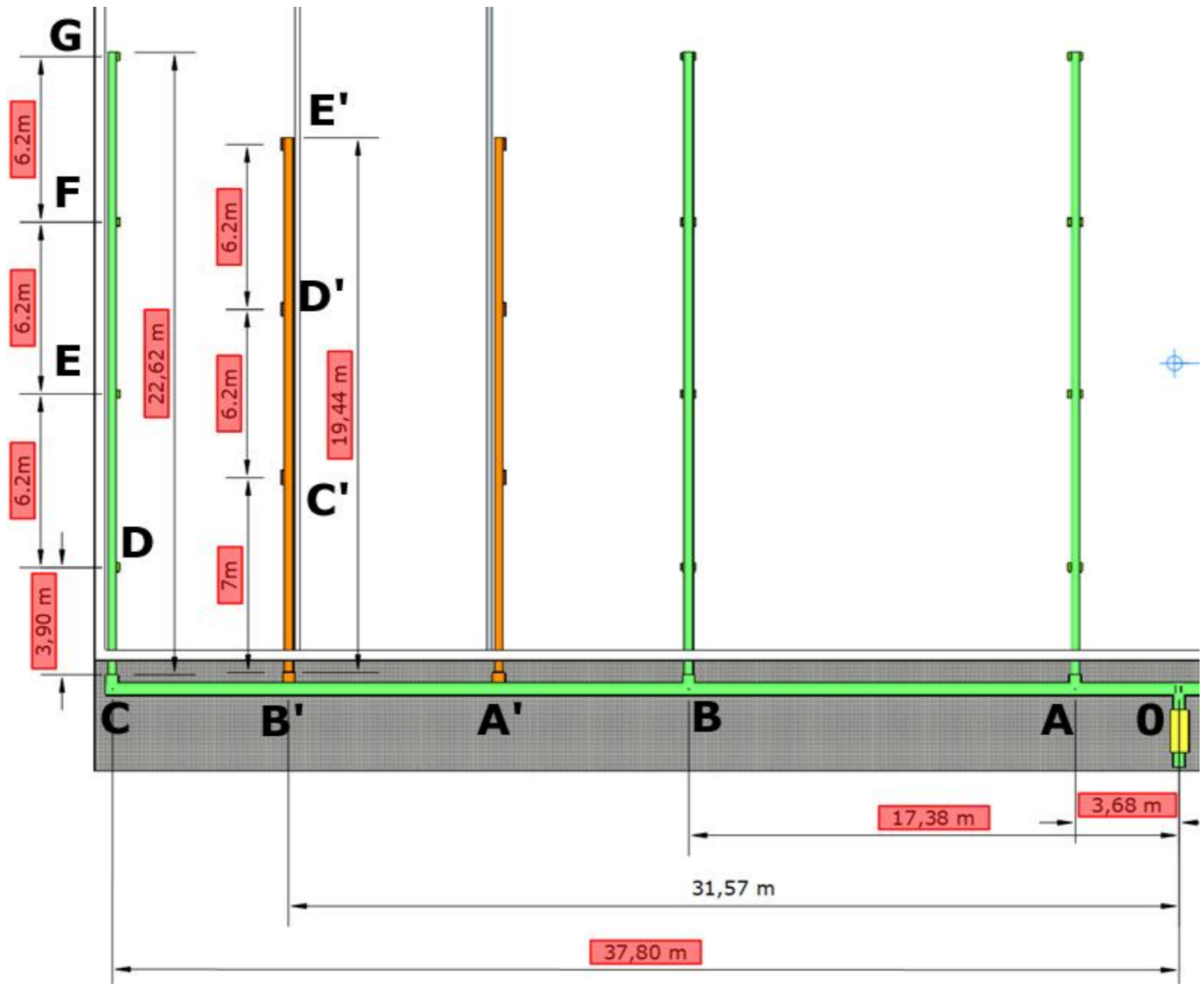

DIMENSIONAMENTO CANALI ARIA SEZ. RETTANGOLARE E CIRCOLARE

http://www.claredot.net/it/sez_Aeraulica/perdita_canali_rett_aria.php

Caratteristiche della tubazione.

Selezione materiale tubo

Note sul materiale

Rugosità assoluta della parete interna mm

Larghezza del canale . . . W mm

Altezza del canale . . . H mm



Velocità del gas nel canale.

Digitare la portata richiesta m³/h

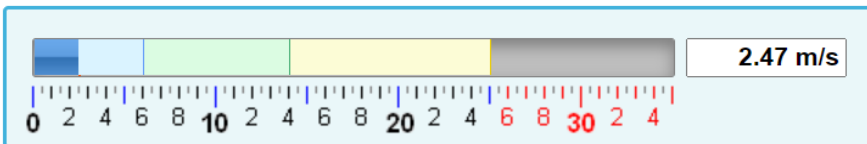

Caratteristiche del gas.

Selezione gas da trasportare

Peso specifico del gas kg/m³

Componenti dell'impianto.

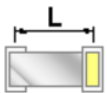

Lunghezza canale rettilineo m



Deviazioni ad angolo n.



Curve a 90° n.

Rapporto R/D R (mm)

Risultati di calcolo

Velocità del gas nel tubo	2.48	m/s
Rugosità relativa della parete interna	0.000077	r/d
Numero di Reynolds	133010	
Coefficiente d'attrito (Colebrook)	0.0176	
Caduta di pressione dinamica totale	0.783	mm H₂O
Diametro a sezione equivalente	801	mm
Diametro idraulico equivalente	776	mm
Sezione del canale	0.504	m ²

DIMENSIONAMENTO CANALI ARIA SEZ. RETTANGOLARE E CIRCOLARE

http://www.claredot.net/it/sez_Aeraulica/perdita_canali_rett_aria.php

Input dati

Caratteristiche della tubazione.

Selezione materiale tubo

Note sul materiale

Rugosità assoluta della parete interna mm

Diametro interno del tubo \varnothing i (mm)

Velocità del gas nel canale.

Digitare la portata richiesta m^3/h

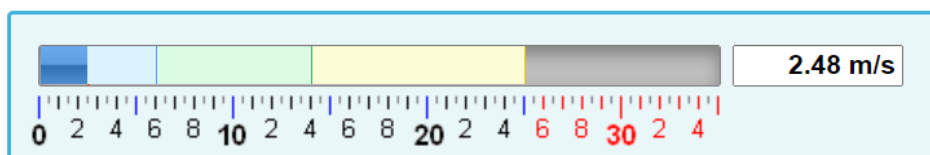

Caratteristiche del gas.

Selezione gas da trasportare

Peso specifico del gas kg/m^3

Componenti dell'impianto.

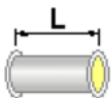

Lunghezza canale rettilineo m



Deviazioni ad angolo retto n.

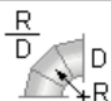

Curve a 90° (in 3 sezioni) n.

Rapporto R/D R (mm)

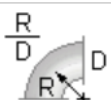

Curve a 90° n.

Rapporto R/D R (mm)

Risultati di calcolo

Velocità del gas nel tubo	2.487	m/s
Rugosità relativa della parete interna	0.000075	r/d
Numero di Reynolds	129045	
Coefficiente d'attrito (Colebrook)	0.0176	
Caduta di pressione dinamica totale	0.647	mm H2O

Moody Diagram

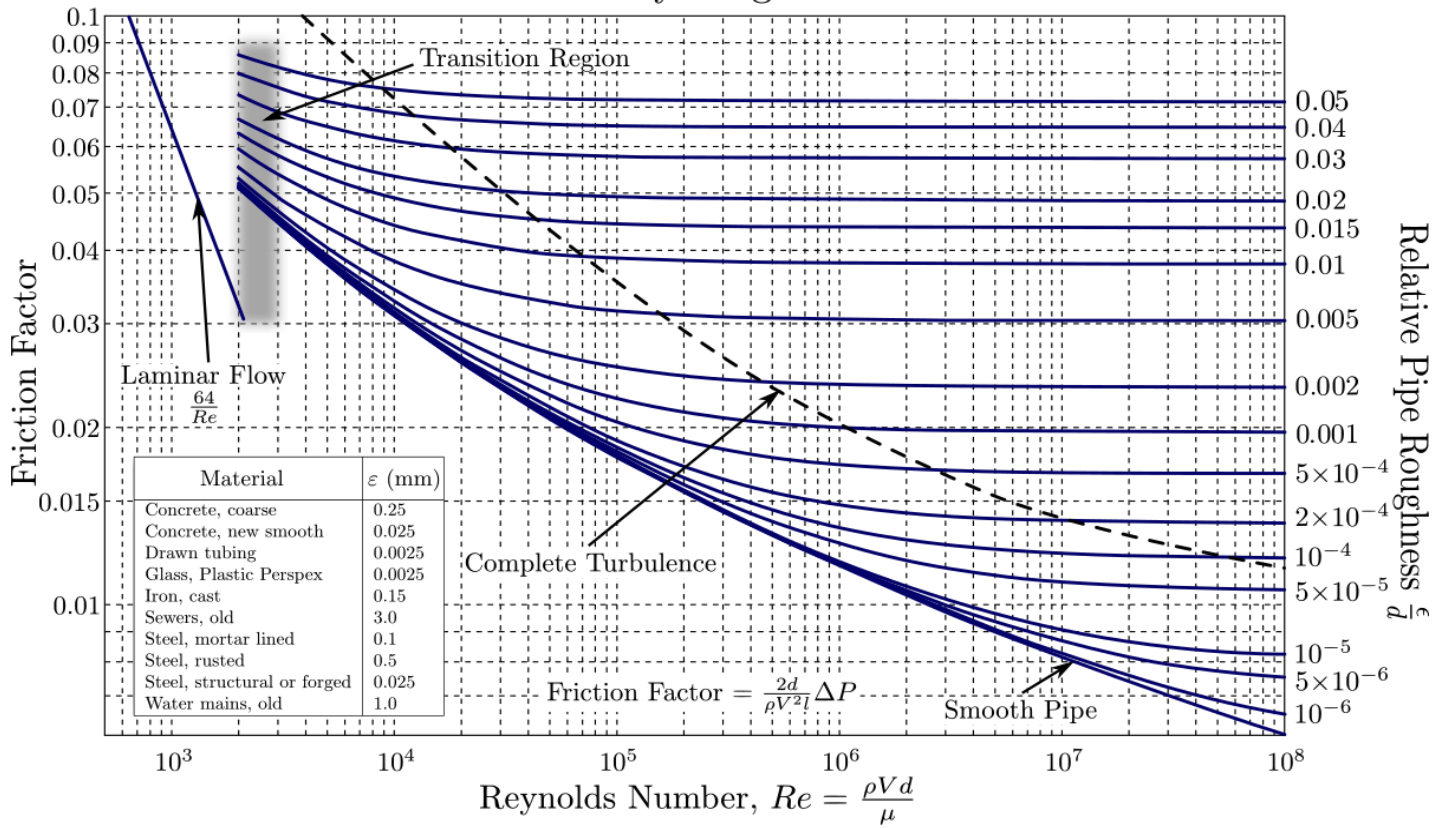

Formula di Jain

$$f = \frac{1,325}{\left[\ln \left(\frac{s}{3,7} + 5,74 Re^{-0,9} \right) \right]^2}$$

Formula Moody

$$f = 5,5 \cdot 10^{-3} \left[1 + \left(200s + \frac{10^6}{Re} \right)^{\frac{1}{3}} \right]$$

Proprietà fluidi

	Aria	Acqua	Mercurio	Olio d'oliva	Glicerina
ρ [Kg m ⁻³]	1.225	999.1	13.61·10 ³	918	1260
μ [Pa s]	1.78·10 ⁻⁵	1.14·10 ⁻³	1.58·10 ⁻³	0.99·10 ⁻¹	2.33
ν [m ² s ⁻¹]	1.45·10 ⁻⁵	1.14·10 ⁻⁶	1.16·10 ⁻⁷	1.08·10 ⁻⁴	1.85·10 ⁻³

	Aria			Acqua		
T [°C]	ρ [Kg m ⁻³]	μ [N m ⁻² s]	ν [m ² s ⁻¹]	ρ [Kg m ⁻³]	μ [N m ⁻² s]	ν [m ² s ⁻¹]
0	1.293	1.71·10 ⁻⁵	1.32·10 ⁻⁵	999.9	1.79·10 ⁻³	1.79·10 ⁻⁶
10	1.247	1.76·10 ⁻⁵	1.41·10 ⁻⁵	999.7	1.30·10 ⁻³	1.30·10 ⁻⁶
20	1.205	1.81·10 ⁻⁵	1.50·10 ⁻⁵	998.2	1.00·10 ⁻³	1.00·10 ⁻⁶
30	1.165	1.86·10 ⁻⁵	1.60·10 ⁻⁵	995.7	0.80·10 ⁻³	0.80·10 ⁻⁶
40	1.127	1.90·10 ⁻⁵	1.69·10 ⁻⁵	992.3	0.65·10 ⁻³	0.66·10 ⁻⁶
60	1.060	2.00·10 ⁻⁵	1.88·10 ⁻⁵	983.2	0.47·10 ⁻³	0.47·10 ⁻⁶
80	1.000	2.09·10 ⁻⁵	2.09·10 ⁻⁵	971.8	0.35·10 ⁻³	0.37·10 ⁻⁶
100	0.946	2.18·10 ⁻⁵	2.30·10 ⁻⁵	958.4	0.28·10 ⁻³	0.29·10 ⁻⁶

Diametro equivalente per le perdite di carico

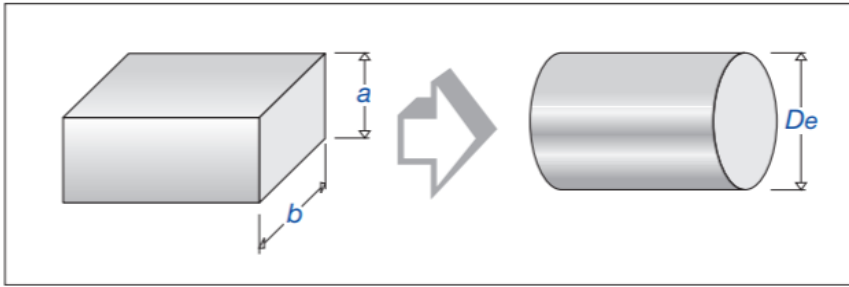

Una simile trasformazione è ottenibile con la formula di Huebscher:

$$De = 1,30 \cdot \frac{(a \cdot b)^{0,625}}{(a + b)^{0,250}} \quad (15)$$



dove: De = diametro canale circolare equivalente, mm
 a, b = lati della sezione rettangolare, mm

Rugosità canali aria

Classi di rugosità per condotti che convogliano aria

Materiale	Classe di rugosità	ϵ [mm]
Canale in PVC Canale in lamiera d'alluminio	molto liscio	0,03
Canale in lamiera zincata Canale in acciaio inox	liscio	0,09
Canale con rivestimento interno in polietilene Canale con rivestimento interno in fibra di vetro Condotto in cemento lisciato	rugoso	0,90
Tubo flessibile metallico Tubo flessibile non metallico Condotto in cemento non lisciato	molto rugoso	3,00

Canali circolari - valori indicativi dei coefficienti ξ - imbocchi e sbocchi

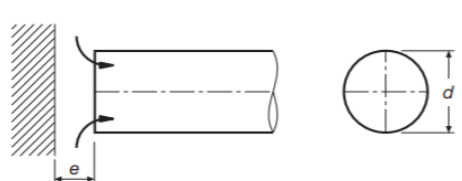
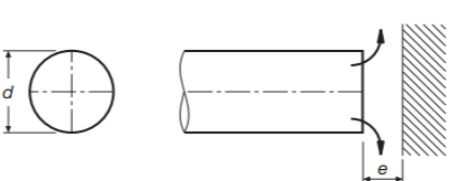
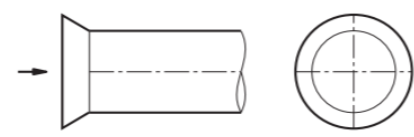
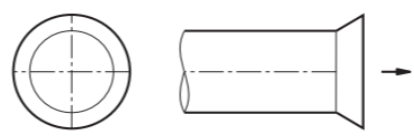
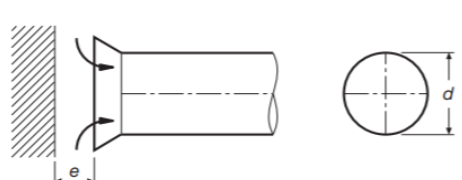
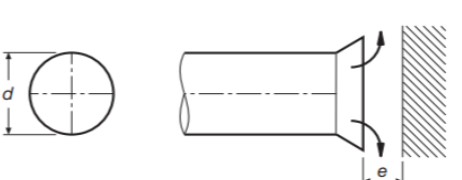
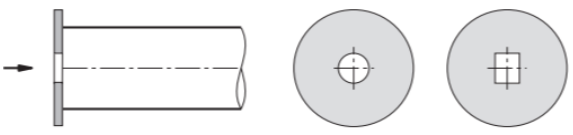
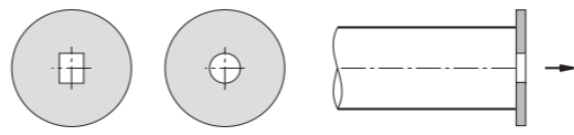
<p>Imbocco senza invito</p>  <p style="text-align: right;">$\xi = 0,8$</p>	<p>Sbocco senza invito</p>  <p style="text-align: left;">$\xi = 1,0$</p>																																
<p>Imbocco senza invito con impedimento frontale</p>  <table border="1" style="margin-left: auto; margin-right: auto;"> <thead> <tr> <th>e/d</th> <th>ξ</th> </tr> </thead> <tbody> <tr><td>0,2</td><td>2,6</td></tr> <tr><td>0,4</td><td>1,5</td></tr> <tr><td>0,6</td><td>1,2</td></tr> <tr><td>0,8</td><td>1,0</td></tr> <tr><td>1,0</td><td>0,8</td></tr> </tbody> </table>	e/d	ξ	0,2	2,6	0,4	1,5	0,6	1,2	0,8	1,0	1,0	0,8	<p>Sbocco senza invito con impedimento frontale</p>  <table border="1" style="margin-left: auto; margin-right: auto;"> <thead> <tr> <th>e/d</th> <th>ξ</th> </tr> </thead> <tbody> <tr><td>0,4</td><td>1,8</td></tr> <tr><td>0,6</td><td>1,4</td></tr> <tr><td>0,8</td><td>1,2</td></tr> <tr><td>1,0</td><td>1,0</td></tr> </tbody> </table>	e/d	ξ	0,4	1,8	0,6	1,4	0,8	1,2	1,0	1,0										
e/d	ξ																																
0,2	2,6																																
0,4	1,5																																
0,6	1,2																																
0,8	1,0																																
1,0	0,8																																
e/d	ξ																																
0,4	1,8																																
0,6	1,4																																
0,8	1,2																																
1,0	1,0																																
<p>Imbocco con invito</p>  <p style="text-align: right;">$\xi = 0,4$</p>	<p>Sbocco con invito</p>  <p style="text-align: left;">$\xi = 0,6$</p>																																
<p>Imbocco con invito e impedimento frontale</p>  <table border="1" style="margin-left: auto; margin-right: auto;"> <thead> <tr> <th>e/d</th> <th>ξ</th> </tr> </thead> <tbody> <tr><td>0,2</td><td>1,2</td></tr> <tr><td>0,4</td><td>0,7</td></tr> <tr><td>0,6</td><td>0,6</td></tr> <tr><td>0,8</td><td>0,5</td></tr> <tr><td>1,0</td><td>0,4</td></tr> </tbody> </table>	e/d	ξ	0,2	1,2	0,4	0,7	0,6	0,6	0,8	0,5	1,0	0,4	<p>Sbocco con invito e impedimento frontale</p>  <table border="1" style="margin-left: auto; margin-right: auto;"> <thead> <tr> <th>e/d</th> <th>ξ</th> </tr> </thead> <tbody> <tr><td>0,4</td><td>1,2</td></tr> <tr><td>0,6</td><td>1,0</td></tr> <tr><td>0,8</td><td>0,8</td></tr> <tr><td>1,0</td><td>0,6</td></tr> </tbody> </table>	e/d	ξ	0,4	1,2	0,6	1,0	0,8	0,8	1,0	0,6										
e/d	ξ																																
0,2	1,2																																
0,4	0,7																																
0,6	0,6																																
0,8	0,5																																
1,0	0,4																																
e/d	ξ																																
0,4	1,2																																
0,6	1,0																																
0,8	0,8																																
1,0	0,6																																
<p>Imbocco con diaframma</p>  <table border="1" style="margin-left: auto; margin-right: auto;"> <thead> <tr> <th>A*/A</th> <th>0,3</th> <th>0,4</th> <th>0,5</th> <th>0,6</th> <th>0,7</th> <th>0,8</th> <th>0,9</th> </tr> </thead> <tbody> <tr> <td>ξ</td> <td>24</td> <td>11</td> <td>6,2</td> <td>3,0</td> <td>2,2</td> <td>1,4</td> <td>1,2</td> </tr> </tbody> </table> <p>A = area sezione canale A* = area passaggio diaframma</p>	A*/A	0,3	0,4	0,5	0,6	0,7	0,8	0,9	ξ	24	11	6,2	3,0	2,2	1,4	1,2	<p>Sbocco con diaframma</p>  <table border="1" style="margin-left: auto; margin-right: auto;"> <thead> <tr> <th>A*/A</th> <th>0,3</th> <th>0,4</th> <th>0,5</th> <th>0,6</th> <th>0,7</th> <th>0,8</th> <th>0,9</th> </tr> </thead> <tbody> <tr> <td>ξ</td> <td>28</td> <td>13</td> <td>7,8</td> <td>3,6</td> <td>2,6</td> <td>1,7</td> <td>1,4</td> </tr> </tbody> </table> <p>A = area sezione canale A* = area passaggio diaframma</p>	A*/A	0,3	0,4	0,5	0,6	0,7	0,8	0,9	ξ	28	13	7,8	3,6	2,6	1,7	1,4
A*/A	0,3	0,4	0,5	0,6	0,7	0,8	0,9																										
ξ	24	11	6,2	3,0	2,2	1,4	1,2																										
A*/A	0,3	0,4	0,5	0,6	0,7	0,8	0,9																										
ξ	28	13	7,8	3,6	2,6	1,7	1,4																										

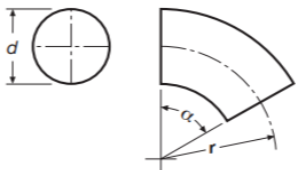
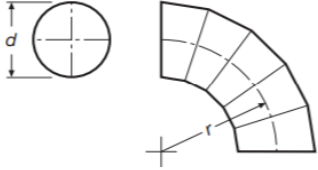
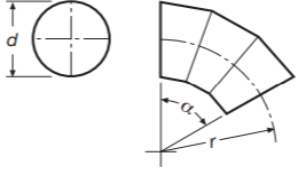
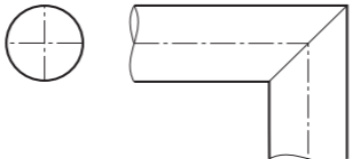
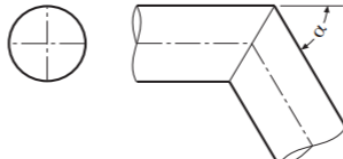
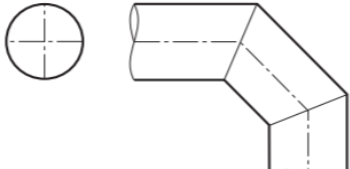
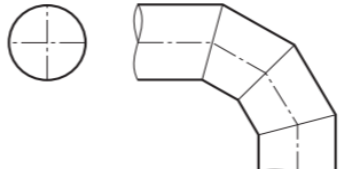
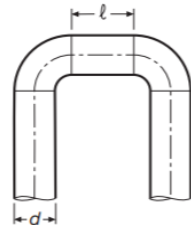
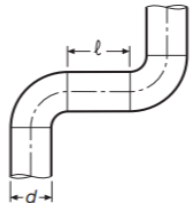

Canali circolari - valori indicativi dei coefficienti ξ - curve

<p style="text-align: center;">Curva a 90°</p> <div style="display: flex; justify-content: space-around; align-items: center;">  <table border="1" style="border-collapse: collapse; text-align: center;"> <thead> <tr> <th>r/d</th> <th>ξ</th> </tr> </thead> <tbody> <tr><td>0,50</td><td>0,9</td></tr> <tr><td>0,75</td><td>0,5</td></tr> <tr><td>1,00</td><td>0,4</td></tr> <tr><td>1,50</td><td>0,3</td></tr> <tr><td>2,00</td><td>0,2</td></tr> </tbody> </table> </div>	r/d	ξ	0,50	0,9	0,75	0,5	1,00	0,4	1,50	0,3	2,00	0,2	<p style="text-align: center;">Curve a 30°, 45° e 60°</p> <div style="display: flex; justify-content: space-around; align-items: center;">  <table border="1" style="border-collapse: collapse; text-align: center;"> <thead> <tr> <th rowspan="2">r/d</th> <th colspan="3">ξ</th> </tr> <tr> <th>$\alpha=30^\circ$</th> <th>$\alpha=45^\circ$</th> <th>$\alpha=60^\circ$</th> </tr> </thead> <tbody> <tr><td>0,50</td><td>0,3</td><td>0,5</td><td>0,7</td></tr> <tr><td>0,75</td><td>0,2</td><td>0,3</td><td>0,3</td></tr> <tr><td>1,00</td><td>0,1</td><td>0,2</td><td>0,3</td></tr> <tr><td>1,50</td><td>0,1</td><td>0,2</td><td>0,2</td></tr> <tr><td>2,00</td><td>0,1</td><td>0,1</td><td>0,1</td></tr> </tbody> </table> </div>	r/d	ξ			$\alpha=30^\circ$	$\alpha=45^\circ$	$\alpha=60^\circ$	0,50	0,3	0,5	0,7	0,75	0,2	0,3	0,3	1,00	0,1	0,2	0,3	1,50	0,1	0,2	0,2	2,00	0,1	0,1	0,1
r/d	ξ																																							
0,50	0,9																																							
0,75	0,5																																							
1,00	0,4																																							
1,50	0,3																																							
2,00	0,2																																							
r/d	ξ																																							
	$\alpha=30^\circ$	$\alpha=45^\circ$	$\alpha=60^\circ$																																					
0,50	0,3	0,5	0,7																																					
0,75	0,2	0,3	0,3																																					
1,00	0,1	0,2	0,3																																					
1,50	0,1	0,2	0,2																																					
2,00	0,1	0,1	0,1																																					
<p style="text-align: center;">Curva a settori a 90°</p> <div style="display: flex; justify-content: space-around; align-items: center;">  <table border="1" style="border-collapse: collapse; text-align: center;"> <thead> <tr> <th>r/d</th> <th>ξ</th> </tr> </thead> <tbody> <tr><td>0,50</td><td>1,1</td></tr> <tr><td>0,75</td><td>0,6</td></tr> <tr><td>1,00</td><td>0,4</td></tr> <tr><td>1,50</td><td>0,3</td></tr> <tr><td>2,00</td><td>0,2</td></tr> </tbody> </table> </div>	r/d	ξ	0,50	1,1	0,75	0,6	1,00	0,4	1,50	0,3	2,00	0,2	<p style="text-align: center;">Curve a settori a 30°, 45° e 60°</p> <div style="display: flex; justify-content: space-around; align-items: center;">  <table border="1" style="border-collapse: collapse; text-align: center;"> <thead> <tr> <th rowspan="2">r/d</th> <th colspan="3">ξ</th> </tr> <tr> <th>$\alpha=30^\circ$</th> <th>$\alpha=45^\circ$</th> <th>$\alpha=60^\circ$</th> </tr> </thead> <tbody> <tr><td>0,50</td><td>0,4</td><td>0,6</td><td>0,7</td></tr> <tr><td>0,75</td><td>0,2</td><td>0,3</td><td>0,4</td></tr> <tr><td>1,00</td><td>0,1</td><td>0,2</td><td>0,3</td></tr> <tr><td>1,50</td><td>0,1</td><td>0,2</td><td>0,2</td></tr> <tr><td>2,00</td><td>0,1</td><td>0,1</td><td>0,1</td></tr> </tbody> </table> </div>	r/d	ξ			$\alpha=30^\circ$	$\alpha=45^\circ$	$\alpha=60^\circ$	0,50	0,4	0,6	0,7	0,75	0,2	0,3	0,4	1,00	0,1	0,2	0,3	1,50	0,1	0,2	0,2	2,00	0,1	0,1	0,1
r/d	ξ																																							
0,50	1,1																																							
0,75	0,6																																							
1,00	0,4																																							
1,50	0,3																																							
2,00	0,2																																							
r/d	ξ																																							
	$\alpha=30^\circ$	$\alpha=45^\circ$	$\alpha=60^\circ$																																					
0,50	0,4	0,6	0,7																																					
0,75	0,2	0,3	0,4																																					
1,00	0,1	0,2	0,3																																					
1,50	0,1	0,2	0,2																																					
2,00	0,1	0,1	0,1																																					
<p style="text-align: center;">Curva con spigolo vivo a 90°</p> <div style="display: flex; justify-content: space-around; align-items: center;">  <div style="text-align: center;"> $\xi = 1,4$ </div> </div>	<p style="text-align: center;">Curve con spigolo vivo a 30°, 45° e 60°</p> <div style="display: flex; justify-content: space-around; align-items: center;">  <table border="1" style="border-collapse: collapse; text-align: center;"> <thead> <tr> <th colspan="3">ξ</th> </tr> <tr> <th>$\alpha=30^\circ$</th> <th>$\alpha=45^\circ$</th> <th>$\alpha=60^\circ$</th> </tr> </thead> <tbody> <tr> <td>0,4</td> <td>0,7</td> <td>1,0</td> </tr> </tbody> </table> </div>	ξ			$\alpha=30^\circ$	$\alpha=45^\circ$	$\alpha=60^\circ$	0,4	0,7	1,0																														
ξ																																								
$\alpha=30^\circ$	$\alpha=45^\circ$	$\alpha=60^\circ$																																						
0,4	0,7	1,0																																						
<p style="text-align: center;">Curva ad un segmento a 90°</p> <div style="display: flex; justify-content: space-around; align-items: center;">  <div style="text-align: center;"> $\xi = 1,3$ </div> </div>	<p style="text-align: center;">Curva a due segmenti a 90°</p> <div style="display: flex; justify-content: space-around; align-items: center;">  <div style="text-align: center;"> $\xi = 1,2$ </div> </div>																																							
<p style="text-align: center;">Curva doppia</p> <div style="display: flex; justify-content: space-around; align-items: center;">  <table border="1" style="border-collapse: collapse; text-align: center;"> <thead> <tr> <th>l/d</th> <th>ξ</th> </tr> </thead> <tbody> <tr><td>< 1</td><td>4,0</td></tr> <tr><td>1 + 2</td><td>3,0</td></tr> <tr><td>> 2</td><td>2,0</td></tr> </tbody> </table> </div>	l/d	ξ	< 1	4,0	1 + 2	3,0	> 2	2,0	<p style="text-align: center;">Curva e controcurva</p> <div style="display: flex; justify-content: space-around; align-items: center;">  <table border="1" style="border-collapse: collapse; text-align: center;"> <thead> <tr> <th>l/d</th> <th>ξ</th> </tr> </thead> <tbody> <tr><td>< 1</td><td>3,5</td></tr> <tr><td>1 + 2</td><td>2,7</td></tr> <tr><td>> 2</td><td>2,0</td></tr> </tbody> </table> </div>	l/d	ξ	< 1	3,5	1 + 2	2,7	> 2	2,0																							
l/d	ξ																																							
< 1	4,0																																							
1 + 2	3,0																																							
> 2	2,0																																							
l/d	ξ																																							
< 1	3,5																																							
1 + 2	2,7																																							
> 2	2,0																																							

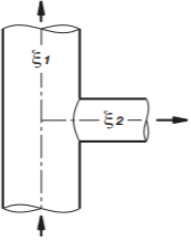
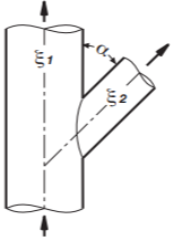
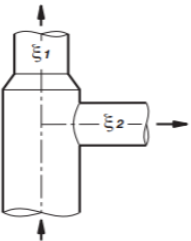
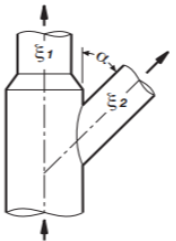
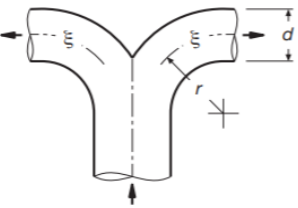
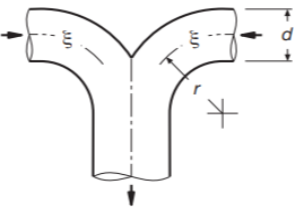
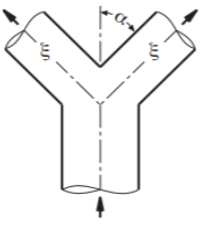
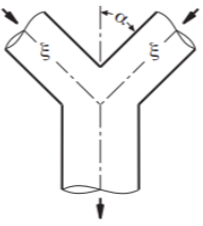
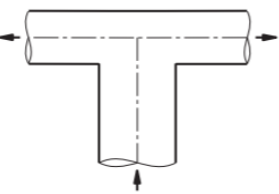
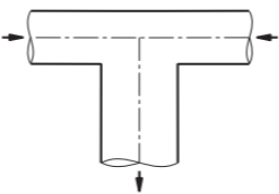
Canali circolari - valori indicativi dei coefficienti ξ - derivazioni e confluenze

 <p style="text-align: center;">Derivazione a 90°</p> <p style="text-align: center;">$\xi_1 = 0,2 \quad \xi_2 = 1,3$</p>	 <p style="text-align: center;">Derivazioni a 30°, 45° e 60°</p> <p style="text-align: center;">$\xi_1 = 0,2$</p> <table border="1" style="margin-left: auto; margin-right: auto;"> <thead> <tr> <th colspan="3">ξ_2</th> </tr> <tr> <th>$\alpha = 30^\circ$</th> <th>$\alpha = 45^\circ$</th> <th>$\alpha = 60^\circ$</th> </tr> </thead> <tbody> <tr> <td>0,4</td> <td>0,7</td> <td>0,9</td> </tr> </tbody> </table>	ξ_2			$\alpha = 30^\circ$	$\alpha = 45^\circ$	$\alpha = 60^\circ$	0,4	0,7	0,9															
ξ_2																									
$\alpha = 30^\circ$	$\alpha = 45^\circ$	$\alpha = 60^\circ$																							
0,4	0,7	0,9																							
 <p style="text-align: center;">Derivazione con riduzione a 90°</p> <p style="text-align: center;">$\xi_1 = 0,4 \quad \xi_2 = 1,3$</p>	 <p style="text-align: center;">Derivazioni con riduzione a 30°, 45° e 60°</p> <p style="text-align: center;">$\xi_1 = 0,4$</p> <table border="1" style="margin-left: auto; margin-right: auto;"> <thead> <tr> <th colspan="3">ξ_2</th> </tr> <tr> <th>$\alpha = 30^\circ$</th> <th>$\alpha = 45^\circ$</th> <th>$\alpha = 60^\circ$</th> </tr> </thead> <tbody> <tr> <td>0,4</td> <td>0,7</td> <td>0,9</td> </tr> </tbody> </table>	ξ_2			$\alpha = 30^\circ$	$\alpha = 45^\circ$	$\alpha = 60^\circ$	0,4	0,7	0,9															
ξ_2																									
$\alpha = 30^\circ$	$\alpha = 45^\circ$	$\alpha = 60^\circ$																							
0,4	0,7	0,9																							
 <p style="text-align: center;">Derivazione a doppia curva</p> <table border="1" style="margin-left: auto; margin-right: auto;"> <thead> <tr> <th>r/d</th> <th>ξ</th> </tr> </thead> <tbody> <tr> <td>0,50</td> <td>1,2</td> </tr> <tr> <td>0,75</td> <td>0,6</td> </tr> <tr> <td>1,00</td> <td>0,4</td> </tr> <tr> <td>1,50</td> <td>0,3</td> </tr> <tr> <td>2,00</td> <td>0,2</td> </tr> </tbody> </table>	r/d	ξ	0,50	1,2	0,75	0,6	1,00	0,4	1,50	0,3	2,00	0,2	 <p style="text-align: center;">Confluenza a doppia curva</p> <table border="1" style="margin-left: auto; margin-right: auto;"> <thead> <tr> <th>r/d</th> <th>ξ</th> </tr> </thead> <tbody> <tr> <td>0,50</td> <td>1,1</td> </tr> <tr> <td>0,75</td> <td>0,5</td> </tr> <tr> <td>1,00</td> <td>0,3</td> </tr> <tr> <td>1,50</td> <td>0,2</td> </tr> <tr> <td>2,00</td> <td>0,2</td> </tr> </tbody> </table>	r/d	ξ	0,50	1,1	0,75	0,5	1,00	0,3	1,50	0,2	2,00	0,2
r/d	ξ																								
0,50	1,2																								
0,75	0,6																								
1,00	0,4																								
1,50	0,3																								
2,00	0,2																								
r/d	ξ																								
0,50	1,1																								
0,75	0,5																								
1,00	0,3																								
1,50	0,2																								
2,00	0,2																								
 <p style="text-align: center;">Derivazione ad Y</p> <table border="1" style="margin-left: auto; margin-right: auto;"> <thead> <tr> <th>α</th> <th>ξ</th> </tr> </thead> <tbody> <tr> <td>30°</td> <td>0,3</td> </tr> <tr> <td>45°</td> <td>0,7</td> </tr> <tr> <td>60°</td> <td>1,0</td> </tr> </tbody> </table>	α	ξ	30°	0,3	45°	0,7	60°	1,0	 <p style="text-align: center;">Confluenza ad Y</p> <table border="1" style="margin-left: auto; margin-right: auto;"> <thead> <tr> <th>α</th> <th>ξ</th> </tr> </thead> <tbody> <tr> <td>30°</td> <td>0,3</td> </tr> <tr> <td>45°</td> <td>0,6</td> </tr> <tr> <td>60°</td> <td>0,9</td> </tr> </tbody> </table>	α	ξ	30°	0,3	45°	0,6	60°	0,9								
α	ξ																								
30°	0,3																								
45°	0,7																								
60°	1,0																								
α	ξ																								
30°	0,3																								
45°	0,6																								
60°	0,9																								
 <p style="text-align: center;">Derivazione a T</p> <p style="text-align: center;">$\xi_1 = 1,4$</p>	 <p style="text-align: center;">Confluenza a T</p> <p style="text-align: center;">$\xi_1 = 1,3$</p>																								

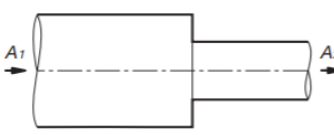
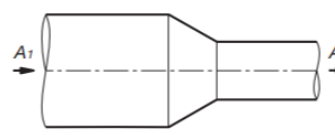
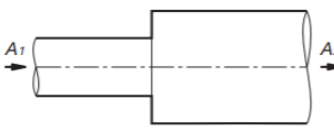
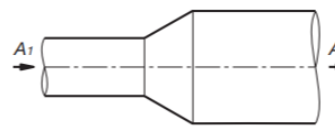
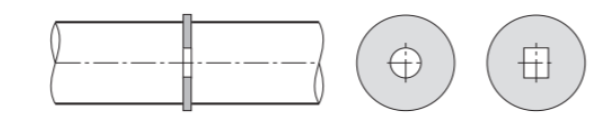
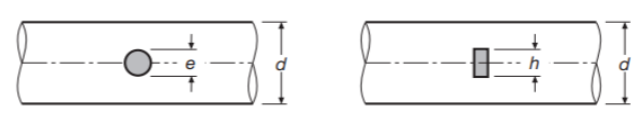
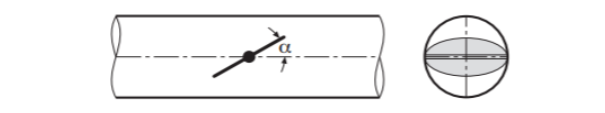
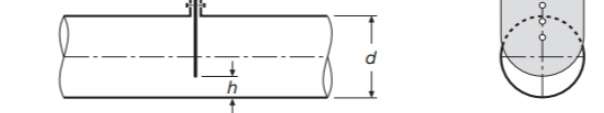
Canali circolari - valori indicativi dei coefficienti ξ - variazioni di sezione e regolatori

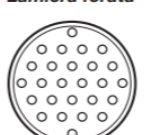
<p>Restringimento senza invito</p>  <table border="1" data-bbox="558 313 686 492"> <thead> <tr> <th>A_2/A_1</th> <th>ξ</th> </tr> </thead> <tbody> <tr><td>0,2</td><td>0,5</td></tr> <tr><td>0,4</td><td>0,4</td></tr> <tr><td>0,6</td><td>0,3</td></tr> <tr><td>0,8</td><td>0,2</td></tr> </tbody> </table>	A_2/A_1	ξ	0,2	0,5	0,4	0,4	0,6	0,3	0,8	0,2	<p>Restringimento con invito</p>  <p>$\xi = 0,2$</p>																																		
A_2/A_1	ξ																																												
0,2	0,5																																												
0,4	0,4																																												
0,6	0,3																																												
0,8	0,2																																												
<p>Allargamento senza invito</p>  <table border="1" data-bbox="558 582 686 761"> <thead> <tr> <th>A_2/A_1</th> <th>ξ</th> </tr> </thead> <tbody> <tr><td>0,1</td><td>0,9</td></tr> <tr><td>0,2</td><td>0,7</td></tr> <tr><td>0,4</td><td>0,4</td></tr> <tr><td>0,6</td><td>0,2</td></tr> </tbody> </table>	A_2/A_1	ξ	0,1	0,9	0,2	0,7	0,4	0,4	0,6	0,2	<p>Allargamento con invito</p>  <table border="1" data-bbox="1260 582 1388 761"> <thead> <tr> <th>A_2/A_1</th> <th>ξ</th> </tr> </thead> <tbody> <tr><td>0,1</td><td>0,5</td></tr> <tr><td>0,2</td><td>0,3</td></tr> <tr><td>0,4</td><td>0,2</td></tr> <tr><td>0,6</td><td>0,2</td></tr> </tbody> </table>	A_2/A_1	ξ	0,1	0,5	0,2	0,3	0,4	0,2	0,6	0,2																								
A_2/A_1	ξ																																												
0,1	0,9																																												
0,2	0,7																																												
0,4	0,4																																												
0,6	0,2																																												
A_2/A_1	ξ																																												
0,1	0,5																																												
0,2	0,3																																												
0,4	0,2																																												
0,6	0,2																																												
<p>Diaframma di equilibratura</p>  <p>A = area sezione canale A^* = area passaggio diaframma</p> <table border="1" data-bbox="95 963 750 1041"> <thead> <tr> <th>A^*/A</th> <th>0,20</th> <th>0,25</th> <th>0,30</th> <th>0,35</th> <th>0,40</th> <th>0,45</th> <th>0,50</th> <th>0,55</th> <th>0,60</th> </tr> </thead> <tbody> <tr> <td>ξ</td> <td>50</td> <td>30</td> <td>20</td> <td>15</td> <td>8</td> <td>7</td> <td>4</td> <td>3</td> <td>2</td> </tr> </tbody> </table>	A^*/A	0,20	0,25	0,30	0,35	0,40	0,45	0,50	0,55	0,60	ξ	50	30	20	15	8	7	4	3	2	<p>Tubi e barre che attraversano canali</p>  <table border="1" data-bbox="813 963 1085 1041"> <thead> <tr> <th colspan="4">Tubi</th> </tr> <tr> <th>e/d</th> <th>0,10</th> <th>0,25</th> <th>0,50</th> </tr> </thead> <tbody> <tr> <td>ξ</td> <td>0,2</td> <td>0,6</td> <td>2,0</td> </tr> </tbody> </table> <table border="1" data-bbox="1149 963 1420 1041"> <thead> <tr> <th colspan="4">Barre</th> </tr> <tr> <th>h/d</th> <th>0,10</th> <th>0,25</th> <th>0,50</th> </tr> </thead> <tbody> <tr> <td>ξ</td> <td>0,7</td> <td>1,4</td> <td>4,0</td> </tr> </tbody> </table>	Tubi				e/d	0,10	0,25	0,50	ξ	0,2	0,6	2,0	Barre				h/d	0,10	0,25	0,50	ξ	0,7	1,4	4,0
A^*/A	0,20	0,25	0,30	0,35	0,40	0,45	0,50	0,55	0,60																																				
ξ	50	30	20	15	8	7	4	3	2																																				
Tubi																																													
e/d	0,10	0,25	0,50																																										
ξ	0,2	0,6	2,0																																										
Barre																																													
h/d	0,10	0,25	0,50																																										
ξ	0,7	1,4	4,0																																										
<p>Regolatore a farfalla</p>  <table border="1" data-bbox="95 1243 750 1310"> <thead> <tr> <th>α</th> <th>0°</th> <th>10°</th> <th>20°</th> <th>30°</th> <th>40°</th> <th>45°</th> <th>50°</th> <th>55°</th> <th>60°</th> </tr> </thead> <tbody> <tr> <td>ξ</td> <td>0,2</td> <td>0,6</td> <td>1,8</td> <td>4,4</td> <td>11</td> <td>21</td> <td>35</td> <td>65</td> <td>105</td> </tr> </tbody> </table>	α	0°	10°	20°	30°	40°	45°	50°	55°	60°	ξ	0,2	0,6	1,8	4,4	11	21	35	65	105	<p>Regolatore a serranda</p>  <table border="1" data-bbox="893 1243 1356 1310"> <thead> <tr> <th>h/d</th> <th>0,2</th> <th>0,3</th> <th>0,4</th> <th>0,5</th> <th>0,6</th> <th>0,7</th> </tr> </thead> <tbody> <tr> <td>ξ</td> <td>30</td> <td>11</td> <td>5,2</td> <td>2,2</td> <td>1,3</td> <td>0,5</td> </tr> </tbody> </table>	h/d	0,2	0,3	0,4	0,5	0,6	0,7	ξ	30	11	5,2	2,2	1,3	0,5										
α	0°	10°	20°	30°	40°	45°	50°	55°	60°																																				
ξ	0,2	0,6	1,8	4,4	11	21	35	65	105																																				
h/d	0,2	0,3	0,4	0,5	0,6	0,7																																							
ξ	30	11	5,2	2,2	1,3	0,5																																							
<p>Rete di protezione</p>  <p>A = area sezione canale A^* = area netta passaggio aria</p> <table border="1" data-bbox="367 1500 750 1568"> <thead> <tr> <th>A^*/A</th> <th>0,2</th> <th>0,3</th> <th>0,4</th> <th>0,5</th> <th>0,6</th> <th>0,7</th> </tr> </thead> <tbody> <tr> <td>ξ</td> <td>17</td> <td>6,5</td> <td>3,0</td> <td>1,7</td> <td>1,0</td> <td>0,8</td> </tr> </tbody> </table>	A^*/A	0,2	0,3	0,4	0,5	0,6	0,7	ξ	17	6,5	3,0	1,7	1,0	0,8	<p>Lamiera forata</p>  <p>A = area sezione canale A^* = area netta passaggio aria</p> <table border="1" data-bbox="1069 1500 1436 1568"> <thead> <tr> <th>A^*/A</th> <th>0,2</th> <th>0,3</th> <th>0,4</th> <th>0,5</th> <th>0,6</th> <th>0,7</th> </tr> </thead> <tbody> <tr> <td>ξ</td> <td>60</td> <td>22</td> <td>9,0</td> <td>4,0</td> <td>2,2</td> <td>1,0</td> </tr> </tbody> </table>	A^*/A	0,2	0,3	0,4	0,5	0,6	0,7	ξ	60	22	9,0	4,0	2,2	1,0																
A^*/A	0,2	0,3	0,4	0,5	0,6	0,7																																							
ξ	17	6,5	3,0	1,7	1,0	0,8																																							
A^*/A	0,2	0,3	0,4	0,5	0,6	0,7																																							
ξ	60	22	9,0	4,0	2,2	1,0																																							

Canali rettangolari - valori indicativi dei coefficienti ξ - imbocchi e sbocchi

<p style="text-align: center;">Imbocco senza invito</p> <p style="text-align: right;">$\xi = 1,00$</p>	<p style="text-align: center;">Sbocco senza invito</p> <p style="text-align: right;">$\xi = 1,20$</p>																																
<p style="text-align: center;">Imbocco senza invito con impedimento frontale</p> <table border="1" style="float: right; margin-top: 10px;"> <thead> <tr> <th>e/d_e</th> <th>ξ</th> </tr> </thead> <tbody> <tr><td>0,2</td><td>2,8</td></tr> <tr><td>0,4</td><td>1,7</td></tr> <tr><td>0,6</td><td>1,4</td></tr> <tr><td>0,8</td><td>1,2</td></tr> <tr><td>1,0</td><td>1,0</td></tr> </tbody> </table> <p>$d_e = \text{diametro equivalente}$</p>	e/d_e	ξ	0,2	2,8	0,4	1,7	0,6	1,4	0,8	1,2	1,0	1,0	<p style="text-align: center;">Sbocco senza invito con impedimento frontale</p> <table border="1" style="float: right; margin-top: 10px;"> <thead> <tr> <th>e/d_e</th> <th>ξ</th> </tr> </thead> <tbody> <tr><td>0,4</td><td>2,0</td></tr> <tr><td>0,6</td><td>1,6</td></tr> <tr><td>0,8</td><td>1,4</td></tr> <tr><td>1,0</td><td>1,2</td></tr> </tbody> </table> <p>$d_e = \text{diametro equivalente}$</p>	e/d_e	ξ	0,4	2,0	0,6	1,6	0,8	1,4	1,0	1,2										
e/d_e	ξ																																
0,2	2,8																																
0,4	1,7																																
0,6	1,4																																
0,8	1,2																																
1,0	1,0																																
e/d_e	ξ																																
0,4	2,0																																
0,6	1,6																																
0,8	1,4																																
1,0	1,2																																
<p style="text-align: center;">Imbocco con invito</p> <p style="text-align: right;">$\xi = 0,6$</p>	<p style="text-align: center;">Sbocco con invito</p> <p style="text-align: right;">$\xi = 0,8$</p>																																
<p style="text-align: center;">Imbocco con invito e impedimento frontale</p> <table border="1" style="float: right; margin-top: 10px;"> <thead> <tr> <th>e/d_e</th> <th>ξ</th> </tr> </thead> <tbody> <tr><td>0,2</td><td>1,4</td></tr> <tr><td>0,4</td><td>0,9</td></tr> <tr><td>0,6</td><td>0,8</td></tr> <tr><td>0,8</td><td>0,7</td></tr> <tr><td>1,0</td><td>0,6</td></tr> </tbody> </table> <p>$d_e = \text{diametro equivalente}$</p>	e/d_e	ξ	0,2	1,4	0,4	0,9	0,6	0,8	0,8	0,7	1,0	0,6	<p style="text-align: center;">Sbocco con invito e impedimento frontale</p> <table border="1" style="float: right; margin-top: 10px;"> <thead> <tr> <th>e/d_e</th> <th>ξ</th> </tr> </thead> <tbody> <tr><td>0,4</td><td>1,4</td></tr> <tr><td>0,6</td><td>1,2</td></tr> <tr><td>0,8</td><td>1,0</td></tr> <tr><td>1,0</td><td>0,8</td></tr> </tbody> </table> <p>$d_e = \text{diametro equivalente}$</p>	e/d_e	ξ	0,4	1,4	0,6	1,2	0,8	1,0	1,0	0,8										
e/d_e	ξ																																
0,2	1,4																																
0,4	0,9																																
0,6	0,8																																
0,8	0,7																																
1,0	0,6																																
e/d_e	ξ																																
0,4	1,4																																
0,6	1,2																																
0,8	1,0																																
1,0	0,8																																
<p style="text-align: center;">Imbocco con diaframma</p> <table border="1" style="float: right; margin-top: 10px;"> <thead> <tr> <th>A^*/A</th> <th>0,3</th> <th>0,4</th> <th>0,5</th> <th>0,6</th> <th>0,7</th> <th>0,8</th> <th>0,9</th> </tr> </thead> <tbody> <tr> <td>ξ</td> <td>24</td> <td>11</td> <td>6,2</td> <td>3,0</td> <td>2,2</td> <td>1,4</td> <td>1,2</td> </tr> </tbody> </table> <p>$A = \text{area sezione canale}$ $A^* = \text{area passaggio diaframma}$</p>	A^*/A	0,3	0,4	0,5	0,6	0,7	0,8	0,9	ξ	24	11	6,2	3,0	2,2	1,4	1,2	<p style="text-align: center;">Sbocco con diaframma</p> <table border="1" style="float: right; margin-top: 10px;"> <thead> <tr> <th>A^*/A</th> <th>0,3</th> <th>0,4</th> <th>0,5</th> <th>0,6</th> <th>0,7</th> <th>0,8</th> <th>0,9</th> </tr> </thead> <tbody> <tr> <td>ξ</td> <td>28</td> <td>13</td> <td>7,8</td> <td>3,6</td> <td>2,6</td> <td>1,7</td> <td>1,4</td> </tr> </tbody> </table> <p>$A = \text{area sezione canale}$ $A^* = \text{area passaggio diaframma}$</p>	A^*/A	0,3	0,4	0,5	0,6	0,7	0,8	0,9	ξ	28	13	7,8	3,6	2,6	1,7	1,4
A^*/A	0,3	0,4	0,5	0,6	0,7	0,8	0,9																										
ξ	24	11	6,2	3,0	2,2	1,4	1,2																										
A^*/A	0,3	0,4	0,5	0,6	0,7	0,8	0,9																										
ξ	28	13	7,8	3,6	2,6	1,7	1,4																										

Canali rettangolari - valori indicativi dei coefficienti ξ - curve

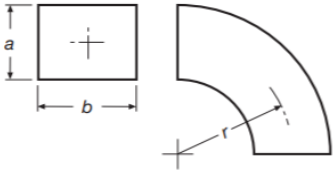
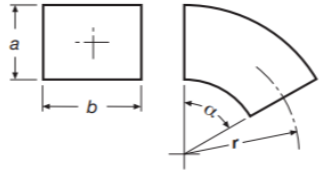
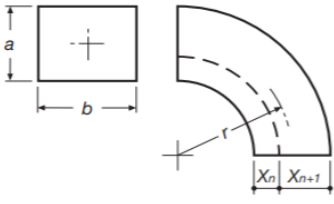
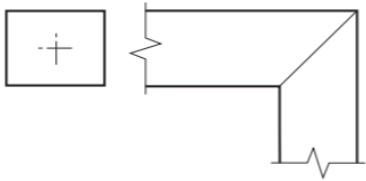
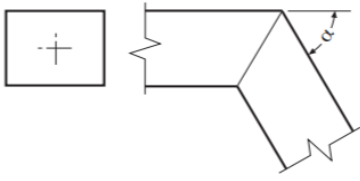
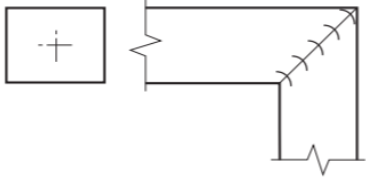
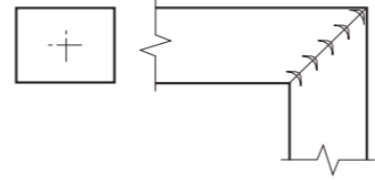
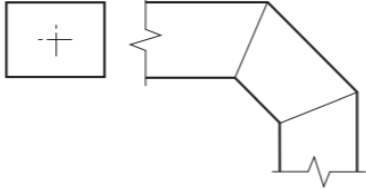
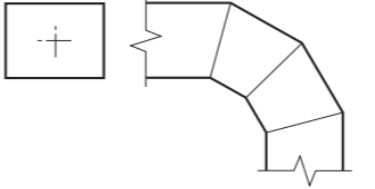
<p style="text-align: center;">Curva a 90°</p> <div style="display: flex; align-items: center; justify-content: space-around;">  <table border="1" style="border-collapse: collapse; text-align: center;"> <thead> <tr> <th rowspan="2">r/a</th> <th colspan="2">ξ</th> </tr> <tr> <th>b/a ≤ 1</th> <th>b/a ≥ 1</th> </tr> </thead> <tbody> <tr> <td>0,50</td> <td>1,2</td> <td>1,0</td> </tr> <tr> <td>0,75</td> <td>0,6</td> <td>0,4</td> </tr> <tr> <td>1,00</td> <td>0,3</td> <td>0,2</td> </tr> <tr> <td>1,50</td> <td>0,1</td> <td>0,1</td> </tr> </tbody> </table> </div>	r/a	ξ		b/a ≤ 1	b/a ≥ 1	0,50	1,2	1,0	0,75	0,6	0,4	1,00	0,3	0,2	1,50	0,1	0,1	<p style="text-align: center;">Curve a 30°, 45° e 60°</p> <div style="display: flex; align-items: center; justify-content: space-around;">  <table border="1" style="border-collapse: collapse; text-align: center;"> <thead> <tr> <th colspan="2">ξ</th> </tr> </thead> <tbody> <tr> <td>$\alpha = 30^\circ$</td> <td>$\xi = \xi(90^\circ) \cdot 0,33$</td> </tr> <tr> <td>$\alpha = 45^\circ$</td> <td>$\xi = \xi(90^\circ) \cdot 0,50$</td> </tr> <tr> <td>$\alpha = 60^\circ$</td> <td>$\xi = \xi(90^\circ) \cdot 0,66$</td> </tr> </tbody> </table> </div>	ξ		$\alpha = 30^\circ$	$\xi = \xi(90^\circ) \cdot 0,33$	$\alpha = 45^\circ$	$\xi = \xi(90^\circ) \cdot 0,50$	$\alpha = 60^\circ$	$\xi = \xi(90^\circ) \cdot 0,66$									
r/a		ξ																																	
	b/a ≤ 1	b/a ≥ 1																																	
0,50	1,2	1,0																																	
0,75	0,6	0,4																																	
1,00	0,3	0,2																																	
1,50	0,1	0,1																																	
ξ																																			
$\alpha = 30^\circ$	$\xi = \xi(90^\circ) \cdot 0,33$																																		
$\alpha = 45^\circ$	$\xi = \xi(90^\circ) \cdot 0,50$																																		
$\alpha = 60^\circ$	$\xi = \xi(90^\circ) \cdot 0,66$																																		
<p style="text-align: center;">Curva a 90° con deflettori</p> <div style="display: flex; align-items: center; justify-content: space-around;">  <table border="1" style="border-collapse: collapse; text-align: center;"> <thead> <tr> <th>a</th> <th>N</th> <th>X₁</th> <th>X₂</th> <th>X₃</th> <th>X₄</th> </tr> </thead> <tbody> <tr> <td>300 ÷ 500</td> <td>1</td> <td>1/3a</td> <td>2/3a</td> <td></td> <td></td> </tr> <tr> <td>500 ÷ 1.000</td> <td>2</td> <td>1/6a</td> <td>1/3a</td> <td>1/2a</td> <td></td> </tr> <tr> <td>> 1.000</td> <td>3</td> <td>1/12a</td> <td>1/6a</td> <td>1/4a</td> <td>1/2a</td> </tr> </tbody> </table> <table border="1" style="border-collapse: collapse; text-align: center; margin-left: 20px;"> <thead> <tr> <th>r/a</th> <th>ξ</th> </tr> </thead> <tbody> <tr> <td>0,50</td> <td>0,5</td> </tr> <tr> <td>0,75</td> <td>0,2</td> </tr> <tr> <td>1,00</td> <td>0,1</td> </tr> <tr> <td>1,50</td> <td>0,1</td> </tr> </tbody> </table> </div> <p style="font-size: small; margin-top: 5px;"> a = altezza sezione canale N = numero deflettori X_n = distanza dei vari passaggi d'aria </p>		a	N	X ₁	X ₂	X ₃	X ₄	300 ÷ 500	1	1/3a	2/3a			500 ÷ 1.000	2	1/6a	1/3a	1/2a		> 1.000	3	1/12a	1/6a	1/4a	1/2a	r/a	ξ	0,50	0,5	0,75	0,2	1,00	0,1	1,50	0,1
a	N	X ₁	X ₂	X ₃	X ₄																														
300 ÷ 500	1	1/3a	2/3a																																
500 ÷ 1.000	2	1/6a	1/3a	1/2a																															
> 1.000	3	1/12a	1/6a	1/4a	1/2a																														
r/a	ξ																																		
0,50	0,5																																		
0,75	0,2																																		
1,00	0,1																																		
1,50	0,1																																		
<p style="text-align: center;">Curva con spigolo vivo a 90°</p> <div style="display: flex; align-items: center; justify-content: space-around;">  <div style="text-align: center;"> $\xi = 1,4$ </div> </div>	<p style="text-align: center;">Curve con spigolo vivo a 30°, 45° e 60°</p> <div style="display: flex; align-items: center; justify-content: space-around;">  <table border="1" style="border-collapse: collapse; text-align: center;"> <thead> <tr> <th colspan="3">ξ</th> </tr> <tr> <th>$\alpha = 30^\circ$</th> <th>$\alpha = 45^\circ$</th> <th>$\alpha = 60^\circ$</th> </tr> </thead> <tbody> <tr> <td>0,5</td> <td>0,7</td> <td>0,9</td> </tr> </tbody> </table> </div>	ξ			$\alpha = 30^\circ$	$\alpha = 45^\circ$	$\alpha = 60^\circ$	0,5	0,7	0,9																									
ξ																																			
$\alpha = 30^\circ$	$\alpha = 45^\circ$	$\alpha = 60^\circ$																																	
0,5	0,7	0,9																																	
<p style="text-align: center;">Curva a 90° con alette normali</p> <div style="display: flex; align-items: center; justify-content: space-around;">  <div style="text-align: center;"> $\xi = 0,4$ </div> </div>	<p style="text-align: center;">Curva a 90° con alette aerodinamiche</p> <div style="display: flex; align-items: center; justify-content: space-around;">  <div style="text-align: center;"> $\xi = 0,2$ </div> </div>																																		
<p style="text-align: center;">Curva a 90° ad un segmento</p> <div style="display: flex; align-items: center; justify-content: space-around;">  <div style="text-align: center;"> $\xi = 1,3$ </div> </div>	<p style="text-align: center;">Curva a 90° a due segmenti</p> <div style="display: flex; align-items: center; justify-content: space-around;">  <div style="text-align: center;"> $\xi = 1,2$ </div> </div>																																		

Canali rettangolari - valori indicativi dei coefficienti ξ - derivazioni e confluenze

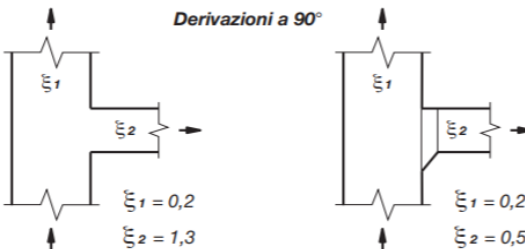
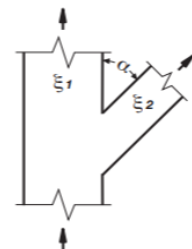
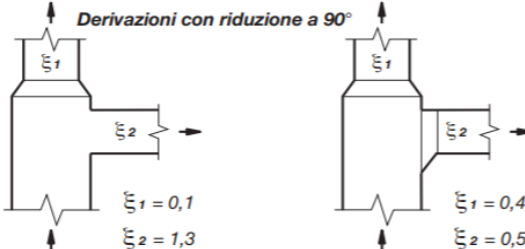
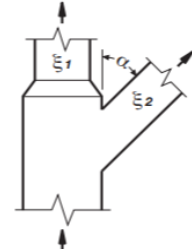
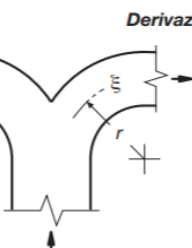
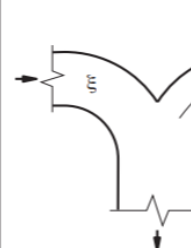
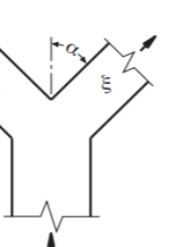
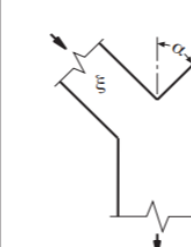
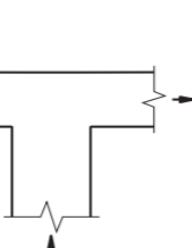
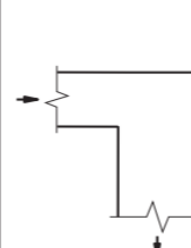
<p>Derivazioni a 90°</p>  <p>$\xi_1 = 0,2$ $\xi_2 = 1,3$</p> <p>$\xi_1 = 0,2$ $\xi_2 = 0,5$</p>	<p>Derivazioni a 30°, 45° e 60°</p>  <p>$\xi_1 = 0,2$</p> <table border="1" data-bbox="1165 380 1356 470"> <thead> <tr> <th colspan="3">ξ_2</th> </tr> <tr> <th>$\alpha = 30^\circ$</th> <th>$\alpha = 45^\circ$</th> <th>$\alpha = 60^\circ$</th> </tr> </thead> <tbody> <tr> <td>0,4</td> <td>0,7</td> <td>0,9</td> </tr> </tbody> </table>	ξ_2			$\alpha = 30^\circ$	$\alpha = 45^\circ$	$\alpha = 60^\circ$	0,4	0,7	0,9															
ξ_2																									
$\alpha = 30^\circ$	$\alpha = 45^\circ$	$\alpha = 60^\circ$																							
0,4	0,7	0,9																							
<p>Derivazioni con riduzione a 90°</p>  <p>$\xi_1 = 0,1$ $\xi_2 = 1,3$</p> <p>$\xi_1 = 0,4$ $\xi_2 = 0,5$</p>	<p>Derivazioni con riduzione a 30°, 45° e 60°</p>  <p>$\xi_1 = 0,4$</p> <table border="1" data-bbox="1165 649 1356 739"> <thead> <tr> <th colspan="3">ξ_2</th> </tr> <tr> <th>$\alpha = 30^\circ$</th> <th>$\alpha = 45^\circ$</th> <th>$\alpha = 60^\circ$</th> </tr> </thead> <tbody> <tr> <td>0,4</td> <td>0,7</td> <td>0,9</td> </tr> </tbody> </table>	ξ_2			$\alpha = 30^\circ$	$\alpha = 45^\circ$	$\alpha = 60^\circ$	0,4	0,7	0,9															
ξ_2																									
$\alpha = 30^\circ$	$\alpha = 45^\circ$	$\alpha = 60^\circ$																							
0,4	0,7	0,9																							
<p>Derivazione a doppia curva</p>  <table border="1" data-bbox="494 851 606 1030"> <thead> <tr> <th>r/a</th> <th>ξ_1</th> </tr> </thead> <tbody> <tr> <td>0,50</td> <td>1,0</td> </tr> <tr> <td>0,75</td> <td>0,5</td> </tr> <tr> <td>1,00</td> <td>0,3</td> </tr> <tr> <td>1,50</td> <td>0,1</td> </tr> <tr> <td>2,00</td> <td>0,1</td> </tr> </tbody> </table>	r/a	ξ_1	0,50	1,0	0,75	0,5	1,00	0,3	1,50	0,1	2,00	0,1	<p>Confluenza a doppia curva</p>  <table border="1" data-bbox="1212 851 1324 1030"> <thead> <tr> <th>r/a</th> <th>ξ_1</th> </tr> </thead> <tbody> <tr> <td>0,50</td> <td>1,0</td> </tr> <tr> <td>0,75</td> <td>0,4</td> </tr> <tr> <td>1,00</td> <td>0,2</td> </tr> <tr> <td>1,50</td> <td>0,1</td> </tr> <tr> <td>2,00</td> <td>0,1</td> </tr> </tbody> </table>	r/a	ξ_1	0,50	1,0	0,75	0,4	1,00	0,2	1,50	0,1	2,00	0,1
r/a	ξ_1																								
0,50	1,0																								
0,75	0,5																								
1,00	0,3																								
1,50	0,1																								
2,00	0,1																								
r/a	ξ_1																								
0,50	1,0																								
0,75	0,4																								
1,00	0,2																								
1,50	0,1																								
2,00	0,1																								
<p>Derivazione ad Y</p>  <table border="1" data-bbox="494 1142 606 1276"> <thead> <tr> <th>α</th> <th>ξ_1</th> </tr> </thead> <tbody> <tr> <td>30°</td> <td>0,3</td> </tr> <tr> <td>45°</td> <td>0,7</td> </tr> <tr> <td>60°</td> <td>1,0</td> </tr> </tbody> </table>	α	ξ_1	30°	0,3	45°	0,7	60°	1,0	<p>Confluenza a Y</p>  <table border="1" data-bbox="1212 1142 1324 1276"> <thead> <tr> <th>α</th> <th>ξ_1</th> </tr> </thead> <tbody> <tr> <td>30°</td> <td>0,3</td> </tr> <tr> <td>45°</td> <td>0,6</td> </tr> <tr> <td>60°</td> <td>0,9</td> </tr> </tbody> </table>	α	ξ_1	30°	0,3	45°	0,6	60°	0,9								
α	ξ_1																								
30°	0,3																								
45°	0,7																								
60°	1,0																								
α	ξ_1																								
30°	0,3																								
45°	0,6																								
60°	0,9																								
<p>Derivazione a T</p>  <p>$\xi_1 = 1,4$</p>	<p>Confluenza a T</p>  <p>$\xi_1 = 1,3$</p>																								

Canali rettangolari - valori indicativi dei coefficienti ξ - variazioni di sezione e regolatori

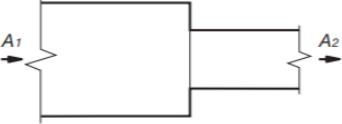
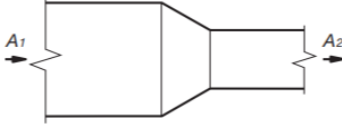
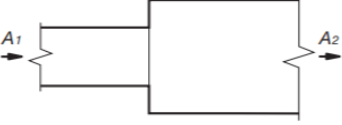
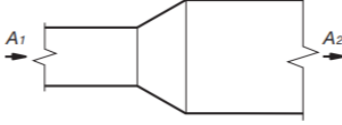
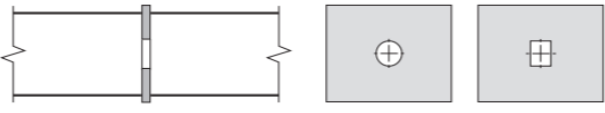
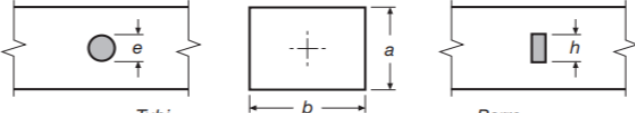
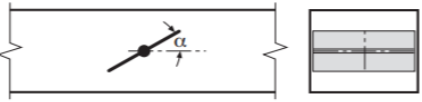
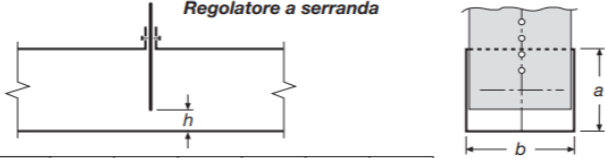
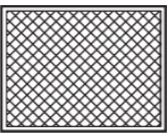
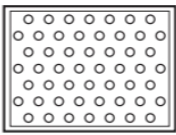
<p>Restringimento senza invito</p>  <table border="1" data-bbox="561 324 683 492"> <thead> <tr> <th>A_2/A_1</th> <th>ξ</th> </tr> </thead> <tbody> <tr> <td>0,2</td> <td>0,5</td> </tr> <tr> <td>0,4</td> <td>0,4</td> </tr> <tr> <td>0,6</td> <td>0,3</td> </tr> <tr> <td>0,8</td> <td>0,2</td> </tr> </tbody> </table>	A_2/A_1	ξ	0,2	0,5	0,4	0,4	0,6	0,3	0,8	0,2	<p>Restringimento con invito</p>  <p>$\xi = 0,2$</p>																										
A_2/A_1	ξ																																				
0,2	0,5																																				
0,4	0,4																																				
0,6	0,3																																				
0,8	0,2																																				
<p>Allargamento senza invito</p>  <table border="1" data-bbox="561 593 683 761"> <thead> <tr> <th>A_2/A_1</th> <th>ξ</th> </tr> </thead> <tbody> <tr> <td>0,1</td> <td>0,9</td> </tr> <tr> <td>0,2</td> <td>0,7</td> </tr> <tr> <td>0,4</td> <td>0,4</td> </tr> <tr> <td>0,6</td> <td>0,2</td> </tr> </tbody> </table>	A_2/A_1	ξ	0,1	0,9	0,2	0,7	0,4	0,4	0,6	0,2	<p>Allargamento con invito</p>  <table border="1" data-bbox="1260 593 1382 761"> <thead> <tr> <th>A_2/A_1</th> <th>ξ</th> </tr> </thead> <tbody> <tr> <td>0,1</td> <td>0,5</td> </tr> <tr> <td>0,2</td> <td>0,3</td> </tr> <tr> <td>0,4</td> <td>0,2</td> </tr> <tr> <td>0,6</td> <td>0,2</td> </tr> </tbody> </table>	A_2/A_1	ξ	0,1	0,5	0,2	0,3	0,4	0,2	0,6	0,2																
A_2/A_1	ξ																																				
0,1	0,9																																				
0,2	0,7																																				
0,4	0,4																																				
0,6	0,2																																				
A_2/A_1	ξ																																				
0,1	0,5																																				
0,2	0,3																																				
0,4	0,2																																				
0,6	0,2																																				
<p>Diaframmi di equilibratura</p>  <p>A = area sezione canale A^* = area passaggio diaframma</p> <table border="1" data-bbox="95 974 746 1048"> <thead> <tr> <th>A^*/A</th> <td>0,20</td> <td>0,25</td> <td>0,30</td> <td>0,35</td> <td>0,40</td> <td>0,45</td> <td>0,50</td> <td>0,55</td> <td>0,60</td> </tr> </thead> <tbody> <tr> <th>ξ</th> <td>50</td> <td>30</td> <td>20</td> <td>15</td> <td>8</td> <td>7</td> <td>4</td> <td>3</td> <td>2</td> </tr> </tbody> </table>	A^*/A	0,20	0,25	0,30	0,35	0,40	0,45	0,50	0,55	0,60	ξ	50	30	20	15	8	7	4	3	2	<p>Tubi e barre che attraversano canali</p>  <table border="1" data-bbox="805 963 1077 1025"> <thead> <tr> <th>e/d_e</th> <td>0,10</td> <td>0,25</td> <td>0,50</td> </tr> </thead> <tbody> <tr> <th>ξ</th> <td>0,2</td> <td>0,6</td> <td>2,0</td> </tr> </tbody> </table> <table border="1" data-bbox="1157 963 1428 1025"> <thead> <tr> <th>h/d_e</th> <td>0,10</td> <td>0,25</td> <td>0,50</td> </tr> </thead> <tbody> <tr> <th>ξ</th> <td>0,7</td> <td>1,4</td> <td>4,0</td> </tr> </tbody> </table> <p>d_e = diametro equivalente</p>	e/d_e	0,10	0,25	0,50	ξ	0,2	0,6	2,0	h/d_e	0,10	0,25	0,50	ξ	0,7	1,4	4,0
A^*/A	0,20	0,25	0,30	0,35	0,40	0,45	0,50	0,55	0,60																												
ξ	50	30	20	15	8	7	4	3	2																												
e/d_e	0,10	0,25	0,50																																		
ξ	0,2	0,6	2,0																																		
h/d_e	0,10	0,25	0,50																																		
ξ	0,7	1,4	4,0																																		
<p>Regolatore a farfalla</p>  <table border="1" data-bbox="95 1243 746 1317"> <thead> <tr> <th>α</th> <td>0°</td> <td>10°</td> <td>20°</td> <td>30°</td> <td>40°</td> <td>45°</td> <td>50°</td> <td>55°</td> <td>60°</td> </tr> </thead> <tbody> <tr> <th>ξ</th> <td>0,2</td> <td>0,6</td> <td>1,8</td> <td>4,4</td> <td>11</td> <td>21</td> <td>35</td> <td>65</td> <td>105</td> </tr> </tbody> </table>	α	0°	10°	20°	30°	40°	45°	50°	55°	60°	ξ	0,2	0,6	1,8	4,4	11	21	35	65	105	<p>Regolatore a serranda</p>  <table border="1" data-bbox="805 1220 1268 1294"> <thead> <tr> <th>h/d_e</th> <td>0,2</td> <td>0,3</td> <td>0,4</td> <td>0,5</td> <td>0,6</td> <td>0,7</td> </tr> </thead> <tbody> <tr> <th>ξ</th> <td>30</td> <td>11</td> <td>5,2</td> <td>2,2</td> <td>1,3</td> <td>0,5</td> </tr> </tbody> </table> <p>d_e = diametro equivalente</p>	h/d_e	0,2	0,3	0,4	0,5	0,6	0,7	ξ	30	11	5,2	2,2	1,3	0,5		
α	0°	10°	20°	30°	40°	45°	50°	55°	60°																												
ξ	0,2	0,6	1,8	4,4	11	21	35	65	105																												
h/d_e	0,2	0,3	0,4	0,5	0,6	0,7																															
ξ	30	11	5,2	2,2	1,3	0,5																															
<p>Rete di protezione</p>  <p>A = area sezione canale A^* = area netta passaggio aria</p> <table border="1" data-bbox="367 1512 746 1585"> <thead> <tr> <th>A^*/A</th> <td>0,2</td> <td>0,3</td> <td>0,4</td> <td>0,5</td> <td>0,6</td> <td>0,7</td> </tr> </thead> <tbody> <tr> <th>ξ</th> <td>17</td> <td>6,5</td> <td>3,0</td> <td>1,7</td> <td>1,0</td> <td>0,8</td> </tr> </tbody> </table>	A^*/A	0,2	0,3	0,4	0,5	0,6	0,7	ξ	17	6,5	3,0	1,7	1,0	0,8	<p>Lamiera forata</p>  <p>A = area sezione canale A^* = area netta passaggio aria</p> <table border="1" data-bbox="1061 1512 1444 1585"> <thead> <tr> <th>A^*/A</th> <td>0,2</td> <td>0,3</td> <td>0,4</td> <td>0,5</td> <td>0,6</td> <td>0,7</td> </tr> </thead> <tbody> <tr> <th>ξ</th> <td>60</td> <td>22</td> <td>9,0</td> <td>4,0</td> <td>2,2</td> <td>1,0</td> </tr> </tbody> </table>	A^*/A	0,2	0,3	0,4	0,5	0,6	0,7	ξ	60	22	9,0	4,0	2,2	1,0								
A^*/A	0,2	0,3	0,4	0,5	0,6	0,7																															
ξ	17	6,5	3,0	1,7	1,0	0,8																															
A^*/A	0,2	0,3	0,4	0,5	0,6	0,7																															
ξ	60	22	9,0	4,0	2,2	1,0																															

Bocchette ARIA MANDATA

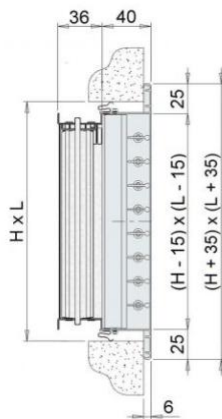

Descrizione:

Bocchetta di mandata dell'aria con 1 o 2 ordini di alette orientabili singolarmente.

Caratteristiche:

Materiale: alluminio
 Finitura: anodizzato naturale
 Installazione: fissaggio a clips
 (su richiesta fori per viti).

Dimensioni realizzabili in pezzo unico:

- min. base 100 mm x altezza 100 mm.
- max. con base da 100 mm a 1000 mm x altezza 1000 mm
- max. con base da >1000 mm a 2000 mm x altezza 600mm.

Impiego:

Per la mandata dell'aria con installazione a parete o a canale negli impianti di ventilazione e condizionamento.

Dati di funzionamento

L1 (m): lancio della bocchetta senza serranda, deflessione delle alette 0°, con effetto coanda (soffitto), velocità terminale 0,25 m/sec e Tmax 15°C

dimensioni LxH	sezione efficace	m³/h	L1	m³/h	L1	dimensioni LxH	sezione efficace	m³/h	L1	m³/h	L1
	m²						m²				
200x100	0.013	100	3	160	5	800x200	0.115	1190	10.3	1827	13
300x100	0.018	140	3.7	230	5.6	1000x200	0.145	930	9.6	1730	15.6
400x100	0.025	200	4.5	320	6.8	400x250	0.065	510	6.2	820	9.2
500x100	0.033	260	6	420	8	500x250	0.081	640	6.8	1020	10
600x100	0.042	335	6.8	500	9	600x250	0.097	770	7.6	1222	11.2
200x150	0.020	160	3.6	240	5.4	300x300	0.058	460	5.8	730	9
300x150	0.029	230	6.8	370	7	400x300	0.085	670	6.8	1070	10
400x150	0.039	310	4.3	500	8	500x300	0.110	870	8.1	1380	12
500x150	0.051	400	5	640	9	600x300	0.136	1080	9.6	1730	15
600x150	0.059	470	5.8	750	9.5	800x300	0.178	1410	10.5	2250	16
800x150	0.086	682	6	1083	11	1000x300	0.226	1790	13	2860	18
200x200	0.026	200	4	300	6	400x400	0.115	910	8	1430	12
300x200	0.044	350	5.8	720	8	600x400	0.18	1430	11	2290	17
400x200	0.057	450	6.5	900	9	800x400	0.245	1940	12	3080	18
500x200	0.071	560	7.5	1083	10	1000x400	0.31	2460	16	3940	20
600x200	0.086	682	10	1450	11						
V (m/s)		2,2	3,5					2,2	3,5		

Livello potenza sonora dB (A)

V m/s	defl. 0°	defl. 20°	defl. 40°
2.2	15/20	18/23	20/25
3.5	20/25	23/28	25/30

Perdita di carico (Pa)

V m/s	defl. 0°	defl. 20°	defl. 40°
2.2	4	5.5	7
3.5	9	13	16

Griglie di RIPRESA ARIA



Descrizione:

Griglie in alluminio per la ripresa dell'aria costruite con alette orizzontali fisse inclinate a 45°.

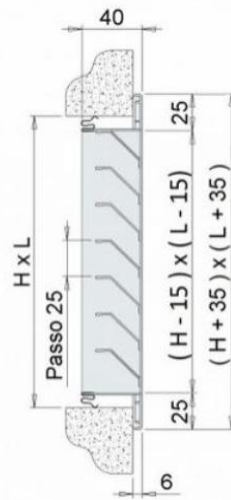

Caratteristiche:

Materiale: alluminio
 Finitura: anodizzato naturale
 Installazione: fissaggio a clips (su richiesta fori per viti).

Dimensioni realizzabili in pezzo unico:

- min. base 100 mm x altezza 100 mm.
- max. base 1500 mm x altezza 1000 mm.

Impiego:

Consigliata per la ripresa dell'aria, può essere installata sia all'interno che all'esterno di ambienti sia civili che industriali.

Accessori:

- Serranda di taratura in acciaio zincato con alette a movimento contrapposto
- Controtelaio a murare
- Plenum isolato e non isolato

A richiesta:

- Verniciatura colore bianco RAL9016 o altri colori RAL a scelta

Dati di funzionamento

Pa: perdite di carico in Pascal
 dB(A): indice di rumorosità
 L: base
 H: altezza

Tutte le dimensioni sono espresse in mm

H	V m/s	L							
		200	300	400	500	600	800	1000	1200
		portata m ³ /h							
100	4	130	200	275	346	420	560	705	850
	6	195	300	410	520	625	840	1060	1275
	8	260	400	545	691	835	1120	1410	1700
200	4	275	430	575	720	880	1165	1470	1770
	6	410	650	860	1080	1320	1750	2203	2660
	8	545	865	1150	1440	1760	2335	2940	3542
300	4	420	650	880	1095	1325	1785	2230	2695
	6	625	970	1320	1640	1990	2680	3350	4040
	8	835	1295	1760	2190	2650	3570	4465	5385
400	4	560	865	1165	1470	1770	2390	2995	3600
	6	840	1295	1750	2200	2655	3585	4495	5400
	8	1120	1730	2335	2940	3540	4780	5990	7200
500	4	705	1080	1470	1845	2230	2995	3760	4520
	6	1060	1620	2200	2765	3350	4495	5640	6780
	8	1410	2160	2940	3685	4465	5990	7515	9040
600	4	850	1310	1770	2220	2680	3600	4505	5430
	6	1275	1965	2660	3325	4020	5400	6760	8140
	8	1700	2620	3545	4435	5360	7200	9015	10860
800	4	1140	1740	2360	2965	3585	4810	6035	7260
	6	1705	2615	3540	4450	5380	7210	9050	10885
	8	2275	3485	4725	5930	7170	9620	12065	14515
1000	4	1430	2190	2950	3715	4490	6020	7560	9085
	6	2140	3280	4430	5570	6740	9030	11340	13630
	8	2850	4380	5905	7430	8985	12040	15120	18170

dB(A): livello potenza sonora
 Pa: perdite di carico in Pascal

V m/s	dB(A)	Pa
4	25/30	16
6	35/45	45
8	45/50	80